



Your Guide to Shaker Furniture



3 Classic Projects

Shaker Hanging Cabinet

If you own any books about the Shakers or their furniture, you probably have seen a small storage cabinet like this one hanging in the background behind the more celebrated pieces.

I first spotted a close relative of this cabinet in William F. Winter's "Shaker Furniture" (Dover). After a long and glowing description of the chairs shown in the same photograph, Winter notes only: "This small, pine, wall cupboard (from the North family, New Lebanon) is a typical convenience of the sisters' shops."

When I visited the Shaker Village of Pleasant Hill (shakervillageky.org) in Harrodsburg, Ky., I saw a similar cabinet hanging on a peg in one of the second-floor rooms. While eating sweet-potato casserole in the Trustees' Office Inn that evening, everyone else at the table was raving about the built-in cabinets; I was smitten with the little hanging cabinet (and the casserole).

Then, years later, I noticed that Thomas Moser published a more refined version in his seminal "How to Build Shaker Furniture" (Sterling).

The way I see it, this small cabinet has what few woodworking projects can truly lay claim to. It is both simple to build and exceptionally well-proportioned. For that, it deserves center stage.

4 Important Lessons

When building this hanging cabinet there are four important things to pay attention to:

■ **Rabbet joinery:** This cabinet – in one way or another – is built using mostly rabbets. Become familiar with this joint before you attempt this project. A good place to begin learning about rabbets is by reading "Cut Accurate and Clean Rabbets," which begins on page 8.

■ **Wood selection:** This cabinet will not look right if you choose the wrong boards for the front. The rails and stiles must have the straightest grain possible. Curvy, diagonal or irregular grain will distract from the simple lines of the piece. Save the most dramatic grain patterns, such as a cathedral grain, for the door's panel.

One common mistake many beginners make is that they try to make a project with as few boards as possible. While no one likes to waste wood, the bigger sin is to build a project that could have looked a lot better in the end. So buy some extra wood and save the scraps for the interior pieces that won't show on a future project.

When picking boards for the two side parts, choose pieces that have straight grain at the edges. This grain pattern will match the straight grain



PHOTO BY AL PARRISH

Story by Christopher Schwarz, executive editor

on the case stiles, making the sides look pleasing and – if you're lucky – almost seamless.

■ **Fitting a door:** Beginners hate fitting doors. Experts know there is a trick to making them right with little fuss. Follow the directions carefully and you'll see how straightforward it can be.

■ **Wood movement:** The back is made from a solid-wood panel, so it will expand and contract about 1/8" with changes in humidity. This means you have to attach the back in a special way to prevent it from splitting or wrenching your cabinet apart as it answers nature's call.

Making a Strong Case

Once you select your boards and joint and plane them down to the correct thickness, you should mill all the parts for the carcass. Joint one long edge of each board, rip them to width and then crosscut them to finished length. Leave the door parts and frame stiles long for now – you will cut them to fit the assembled carcass.

The first joints to cut with this project are the three rabbets in each side piece. Set up your table saw to cut a $\frac{3}{4}$ "-wide x $\frac{1}{4}$ "-deep rabbet using the instructions provided in "Cut Accurate and Clean Rabbets." Make a test cut in some scrap that's the same thickness as your sides. Check your work with a square and some care. If this joint does not have a dead-on 90° corner, your carcass won't have one either. If it is square, check the dimension of the rabbet using a dial caliper. This might sound like overkill, but it's not. Here's why: If this joint is just a little off, then all the joints that follow it will have to compensate for this small error – especially when you start building the door and fitting it to the case. Small errors like this tend to add up during the course of a project.

When you're satisfied with the setup of your dado stack and rip fence, lock the height of the arbor. This is important for a couple of reasons. With some less-expensive table saws, you can actually force the arbor to creep downward during a cut with a dado stack. I've seen it happen – your dado will look like a ramp for skateboarders instead of a properly made joint. Also, you will be keeping this exact height for the next two joinery operations, so locking in your setting is a good idea. With your saw set, cut this rabbet on the ends of the two side pieces. This joint holds the top and bottom of the case in place.

Next, cut the rabbet in the sides that will hold the back panel. To create this rabbet, you need only adjust your rip fence to make a $\frac{1}{2}$ "-wide x $\frac{1}{4}$ "-deep rabbet and cut that rabbet on the long back edge of each side piece.

After that, cut the dados in the side pieces that will hold the two $\frac{1}{2}$ "-thick shelves in place. To make your life easier, make sure you do not change the height of the dado stack you just used to cut the rabbets. Remove the dado stack from the arbor and install the correct number of wings, chippers and shims to produce a perfect $\frac{1}{2}$ "-wide dado.

The dados for the shelves are $\frac{1}{4}$ " deep. By leaving the height of the blades alone, you ensure that the shelves, top and bottom will keep your case square. If you change the height of the blades even a tiny bit before cutting the dados, one of two bad things will happen. If your cut is too deep, your shelves won't seat all the way down into the bottoms of the dados without some extraordinary clamping pressure. (If you manage to close this joint, your carcass will end up with an hourglass shape and the rabbets at the top and bottom will be gappy and weak.) If your dado cut is too shallow, the shelves will cause the sides to

bulge out in the center and the rabbets at the top and bottom will be gappy, unattractive and weak.

To make the dados (set to 90°) and a gauge block clamped to your rip fence, as shown in the photo below. Mark on your side pieces the locations of both dados. Sure, it will take an extra minute, but it prevents mistakes. Also mark the top and bottom of each of the sides so you don't get the right and left sides confused – a common mistake that even professionals make.

With the dados cut, you are almost ready to assemble the basic carcass. It's always a good idea to prepare your interior surfaces for finishing before assembly. Finish-sand the inside faces of your pieces (start with #100-grit paper and work up to #220), or plane and scrape the surfaces to your liking.

Test the fit of the joints and clamp the case together without any glue. Do not skip this step. A rehearsal is worthwhile for several reasons: You'll figure out exactly how many clamps you need so you don't have to go rushing across the room for more as the glue sets up. You'll also figure out the best procedure for clamping the case without your parts flopping around. And you'll make sure your rabbets and dados fit soundly.

As you make this milk run, make sure you keep the front edges of the top, bottom and shelves perfectly flush with the front edge of the side pieces. The top, bottom and shelves, if you haven't noticed, are $\frac{1}{2}$ " narrower than the sides.

Before you take the clamps off, pay particular attention to the squareness of the case. Measure the case from corner to corner and compare the two dimensions. If they're the same, everything's square. If they're not, put a clamp across the two



I recommend using a dado stack for cutting rabbets because it requires only one setup. The featherboard makes the operation safer and more accurate by keeping your work pressed firmly against the saw's table.

corners that produced the longer measurement and apply the tiniest bit of clamping pressure. Compare the corner-to-corner measurements again. Repeat until everything is perfect. I like to check the squareness now because the cabinet usually behaves the same once you add the glue.

Now add glue in your rabbets and dados. If you are new to woodworking, I recommend a slow-setting glue for casework. There are several varieties, the most common being Titebond Extend. The glue's extra "open time," which is when the glue is wet and your parts can move

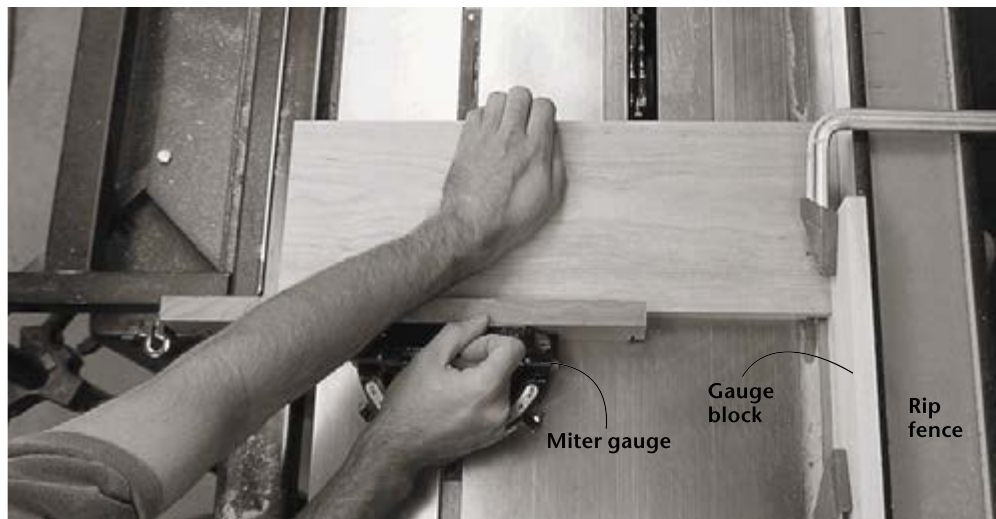

The gauge block, which is clamped to the rip fence, sets the location of the dado on the side pieces. But because the gauge block sits in front of the saw blade, there's no danger of trapping your side piece between the rip fence and the blade

while making this cut – a major source of kickback. If you have a stock miter gauge, this would be an excellent time to add a piece of adhesive sandpaper (I prefer #100-grit) to its smooth metal face to improve grip during this operation.

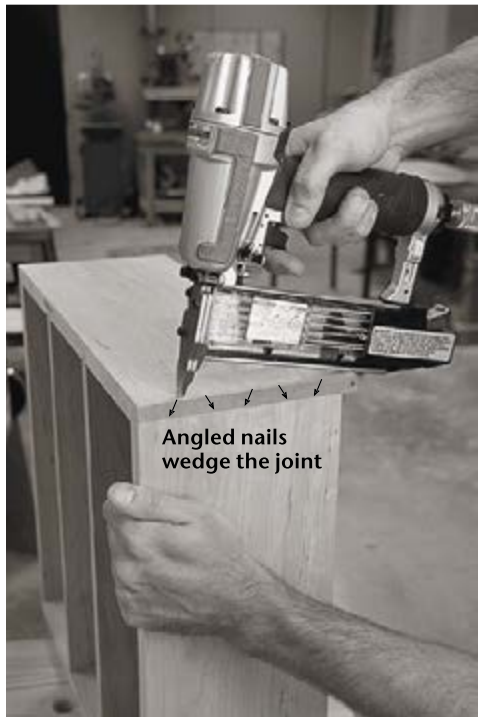

Nails are not an act of the devil. Someday the glue will fail, and it's the nails that will hold everything together. Make sure you angle your nails (18-gauge brads are good) as shown so that the fasteners wedge the side piece against its mates.

around, will allow you to tweak the position of your parts. When applying the glue, a thin but consistent film will bond your joints without making a big mess. When you apply the clamps, a little glue squeeze-out is good – it means you haven't starved your joints of glue.

After 45 minutes, take the case out of the clamps and nail the sides to the top and bottom pieces, using the above photo as a guide.

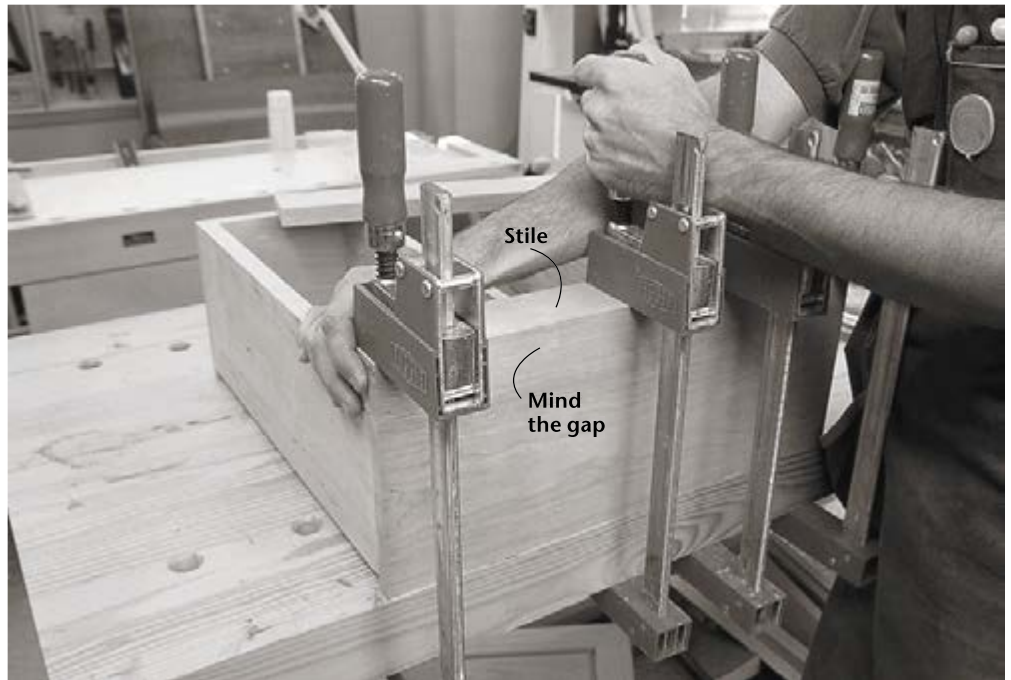

This is a highly visible joint, so make extra sure you watch out for gaps between the stiles and the sides.

World's Simplest Face Frame

Traditionally, face frames are built using both vertical pieces (stiles) and horizontal pieces (rails). Not so with this project, which has only stiles. This makes things a lot easier.

Cut your stiles to finished width and length, and finish-sand or plane them. If you're handy with a block plane, it's wise to cut your stiles about $\frac{1}{32}$ " long and trim them flush to the case at the top and bottom after affixing them to the carcass. If you're not so confident, just take extra care in cutting your stiles to length.

Attach the stiles to the carcass using glue and clamps. Nails aren't necessary here. Make an

effort to ensure the long edge of each stile is perfectly flush with its mating side piece; otherwise the opening for your door will not be square.

To complete the opening for the cabinet's door, you need to attach the additional $\frac{1}{2}$ "-thick top and bottom pieces that have the decorative cove cut milled on them, which is easy to do.

As you study the cutting list below, you'll notice that the outside top and bottom are different widths – the top is $\frac{1}{2}$ " wider than the bottom. That's not a mistake. It's actually a clever way to create a notch in the back edge of the outside top piece (cutting stopped notches is no fun). Let me tell you what you're going to do to that top piece:

Shaker Hanging Cabinet

NO.	PART	SIZES (INCHES)			MATERIAL	NOTES (DIMS IN INCHES)
		T	W	L		
Carcass						
□ 2	Sides	$\frac{3}{4}$	7	19	Cherry	$\frac{3}{4}$ "-wide x $\frac{1}{4}$ "-deep rabbets on ends
□ 2	Inside top & bottom	$\frac{3}{4}$	$6\frac{1}{2}$	17	Cherry	
□ 2	Shelves	$\frac{1}{2}$	$6\frac{1}{2}$	17	Cherry	Cherry in $\frac{1}{2}$ "-wide x $\frac{1}{4}$ " - deep dados
□ 2	Stiles	$\frac{3}{4}$	$21\frac{1}{2}$	19	Cherry	Glued to carcass
□ 1	Notched outside top	$\frac{1}{2}$	$8\frac{3}{4}$	19	Cherry	
□ 1	Outside bottom	$\frac{1}{2}$	$8\frac{1}{4}$	19	Cherry	
□ 1	Back	$\frac{1}{2}$	18	$24\frac{1}{2}$	Cherry	
Door						
□ 2	Door stiles	$\frac{3}{4}$	$1\frac{1}{2}$ *	20*	Cherry	$\frac{1}{4}$ " -wide x $\frac{1}{2}$ "-deep groove on one edge
□ 2	Door rails	$\frac{3}{4}$	$1\frac{1}{2}$ *	$11\frac{1}{4}$ *	Cherry	$\frac{1}{4}$ " -wide x $\frac{1}{2}$ "-deep groove on one edge, $\frac{1}{2}$ " TBE
□ 1	Door panel	$\frac{1}{2}$	11	17	Cherry	$\frac{1}{2}$ "-wide x $\frac{1}{4}$ " -deep rabbet on four back edges

* Dimensions listed are oversized. See the text for details. TBE = tenon both ends

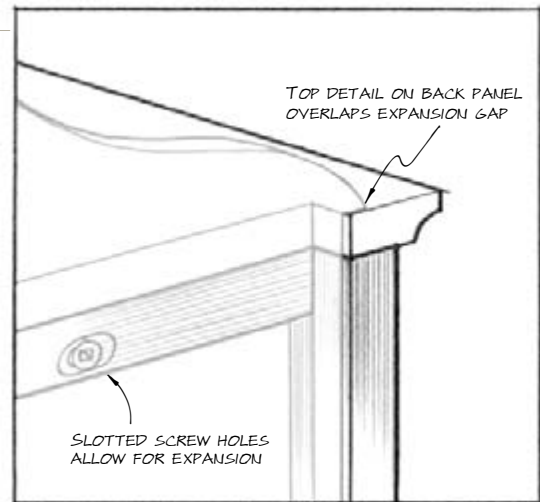
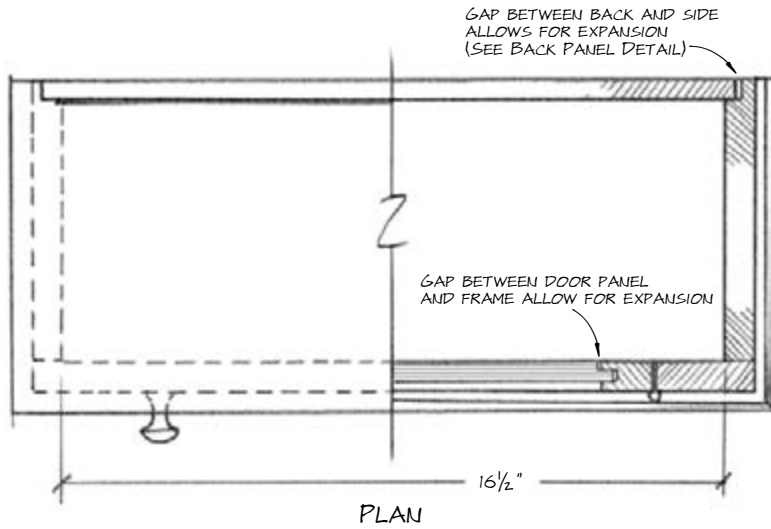

BACK PANEL DETAIL

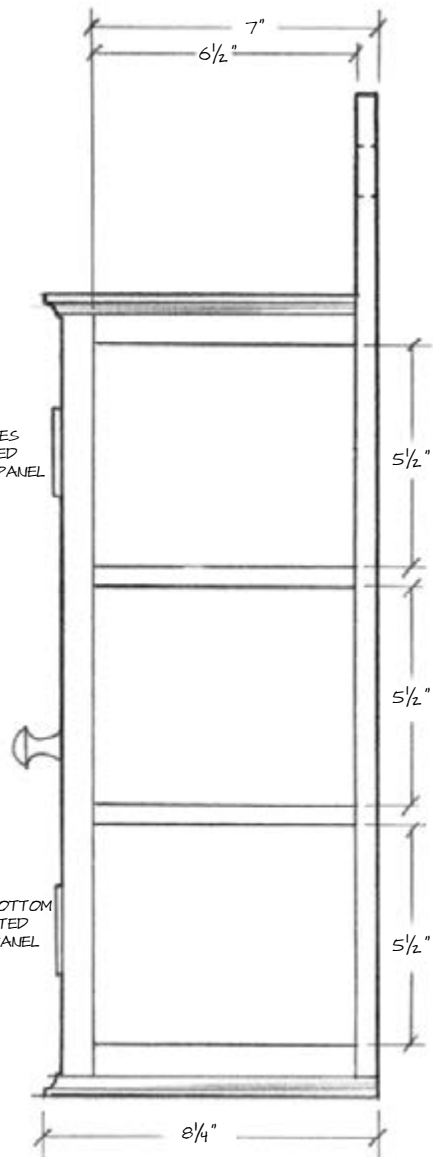
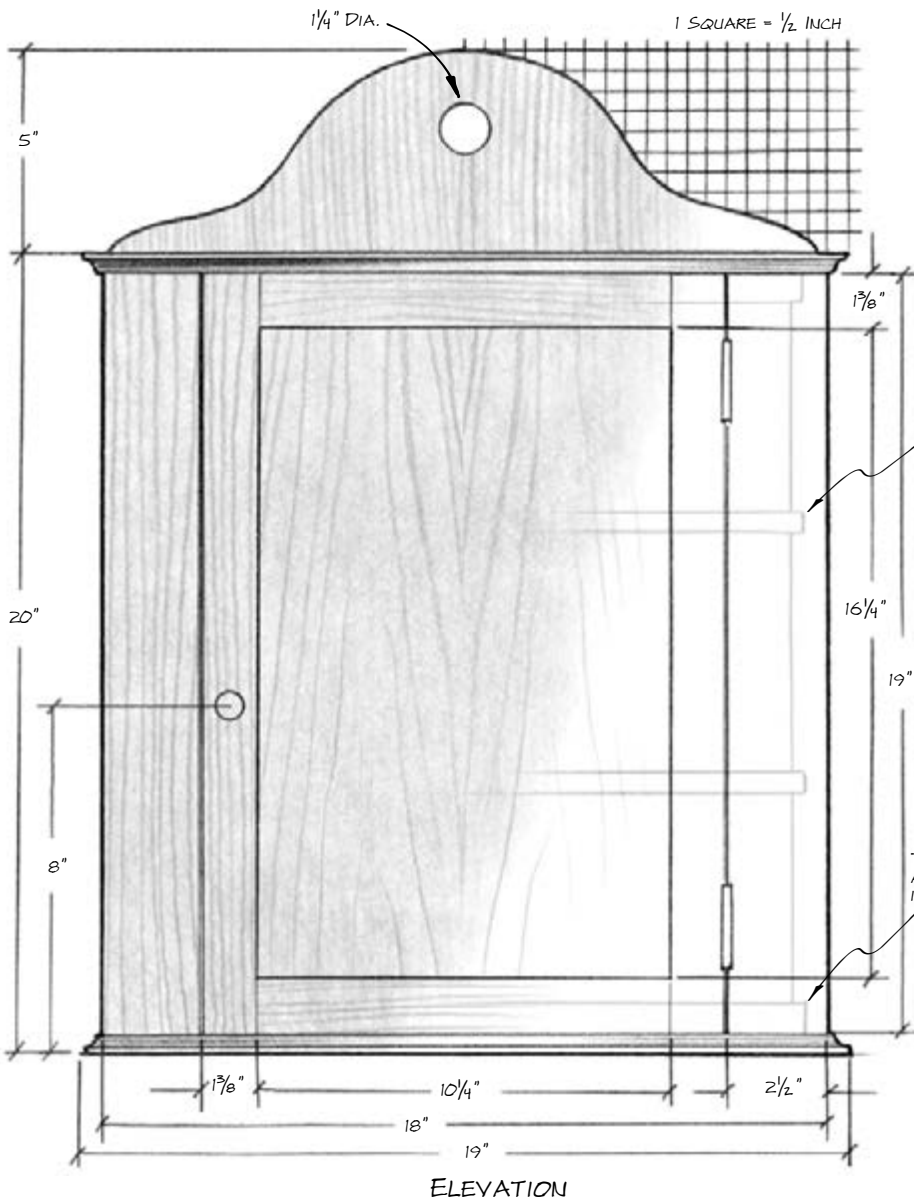

ALL SHELVES ARE DADOED INTO SIDE PANEL

TOP AND BOTTOM ARE RABBETED INTO SIDE PANEL

SHAKER HANGING CABINET



Cutting an accurate stopped notch like this is a pain. By ripping the oversized top down and regluing smaller blocks on the ends of the top, you create the perfect notch for the back piece.



Centering grooves on your work is child's play if you cut them in two passes. Here you can see that I milled one half of the groove and have turned the piece around to mill the other half.



Make the tenons by cutting a rabbet on both sides of the rails. Use your miter gauge and fence to make this cut. It's a safe operation because you can't trap your work between the blade and fence.

First you're going to rout the cove detail on three edges of both the top and bottom.

The best way to do this operation is on a router table that's set up with a $\frac{3}{8}$ " cove bit, though you can do it hand-held in a pinch. Either way, make sure you rout the detail on the ends first, then come back and rout the long edge. This will clean up a good deal of splintering that occurs when you exit the cuts on the ends.

Next take only the top piece to the table saw and rip the back edge off the board so it's $\frac{7}{8}$ " wide. Take the fall-off strip and rip it so it's $\frac{1}{2}$ " wide. Crosscut 1" off each end of that falloff piece and reglue each end to the back edge of the top piece, making sure the cove detail matches. Voilà! You have an instant stopped notch in your top.

Attaching the top and bottom pieces to the carcass is easy if your case is square and your joints are flush. Before you attach the top and bottom, check their fit against the carcass itself. You want a tight joint at the front and the sides. If you don't get a seamless fit with only hand pressure, you'll need to tweak the carcass until you do. Relying on your clamps to close an imperfect joint is asking for trouble.

Sometimes this process takes a bit of detective work to figure out what's wrong. For example, the top of my carcass had an inexplicable

but slight bulge in the center, so the top piece would rock back and forth on it. A sharp block plane made short work of the problem. As you remove material, try to stay away from the edges of the carcass. That's where you can create problems that will show in the finished piece.

When satisfied with the fit of the top and bottom pieces, apply a liberal amount of glue to the carcass and position the top and bottom in place. When you've got them where you want them, nail them in place through the inside of the cabinet. Use only a couple of nails in each; their job is to hold the top in place as you clamp it. Apply clamps around the cabinet to secure the top and bottom to the carcass and check for gaps.

The Stub-tenon Door

Because this is a light-duty door, we can build what's called a "stub-tenon" door. Essentially, it's a traditional mortise-and-tenon door that uses short (some would say "stubby") tenons that are only $\frac{1}{2}$ " long. A bigger traditional door would use tenons at least 1" long. We've included a tutorial on this style of door starting on page 12.

The advantage to these short tenons is they allow you to build the door without having to cut mortises in the stiles. The $\frac{1}{4}$ "-wide x $\frac{1}{2}$ "-deep groove you cut for the door's panel also serves as the mortise for the tenons on the rails.

While stub-tenon doors are a good trick, the real trick to making perfect doors is to learn about "horns." What are horns? Again, take a look at the cutting list and you'll notice that the stiles are 1" longer than they need to be to fit in the door's opening. And both the rails and stiles are $\frac{1}{8}$ " wider than called for in the drawing.

This extra length and width create what look like horns on the assembled door. These horns allow you to make a door that is slightly oversized when compared to the hole in the cabinet. Once the door is assembled, rip and crosscut it

square to fit perfectly in the door opening. There is no easier way to fit a door.

So let's build the door. Cut your stiles, rails and panel to the sizes listed in the cutting list. Now mill the $\frac{1}{4}$ "-wide x $\frac{1}{2}$ "-deep groove in one long edge of the rails and stiles. The best way to do this is with a rip blade set to make a $\frac{1}{2}$ "-deep cut. A rip blade is best because the top of its teeth are flat, so the bottom of your groove also will be flat. Crosscut teeth will leave "V"-shaped channels in the bottom of the groove. Position your saw's rip fence so there's a $\frac{1}{4}$ "-wide gap between the teeth and the rip fence.

Cut the groove first with one face of your work against the fence, then turn it around and make the cut with the other face against the fence. This method ensures that the groove is perfectly centered on your rails and stiles. If there happens to be a thin scrap hanging in the middle (as shown in the photo above center), you can adjust the fence and make a third pass to eliminate it.

Next get your rails and prepare to cut the tenons on the ends. These tenons are made by cutting a rabbet on both faces of the board. Two rabbets make a tenon, as shown in the photo above right.

Set up your dado stack with an accessory fence just like you did when you cut the rabbets on the side pieces. Bury the dado stack in the accessory fence so that you're making a cut that is exactly $\frac{1}{2}$ " wide x $\frac{1}{4}$ " deep.

Use your miter gauge to guide your rails across the spinning dado stack. Make a couple of test cuts on scrap that is the same thickness as your door stock. Test the fit of your scrap tenon in the grooves you cut in the rails. Fine-tune your fence setup and cut the tenons on the ends of both rails.

Now fetch your $\frac{1}{2}$ "-thick panel. To fit this panel in the grooves in the rails and stiles you must first cut a rabbet that is $\frac{1}{2}$ " wide x $\frac{1}{4}$ " deep

"Skill without imagination is craftsmanship and gives us many useful objects such as wickerwork picnic baskets. Imagination without skill gives us modern art."

— Tom Stoppard (1937–)
"Artist Descending a Staircase"

on the panel's four back edges. Coincidentally (OK, it's not really a coincidence), this is the same setup you just used to make your tenons.

Now finish-sand your door parts and dry-fit the door. You'll notice how the stiles extend past the rails. These are the horns I told you about earlier. The tenons must close tightly with only minimal clamping pressure. If you are straining to close the joint you are almost certainly twisting your door so it's not flat. Take the joint apart and investigate the problem. Usually there's gunk that's preventing a good fit, or the tenon is too long for the depth of the groove.

Once you have a seamless door frame clamped up, take the whole thing apart and glue the tenons in the grooves. (Never glue a solid-wood panel in place in a door. It has to expand and contract with changes in humidity.)

After about 45 minutes, remove the clamps from the door. Measure your door opening and temporarily screw the hinges to the carcass. Now true one stile of your assembled door by running it over the jointer. Rip the door to its finished width on your table saw, trimming evenly from the left and right stile. Then crosscut it to the

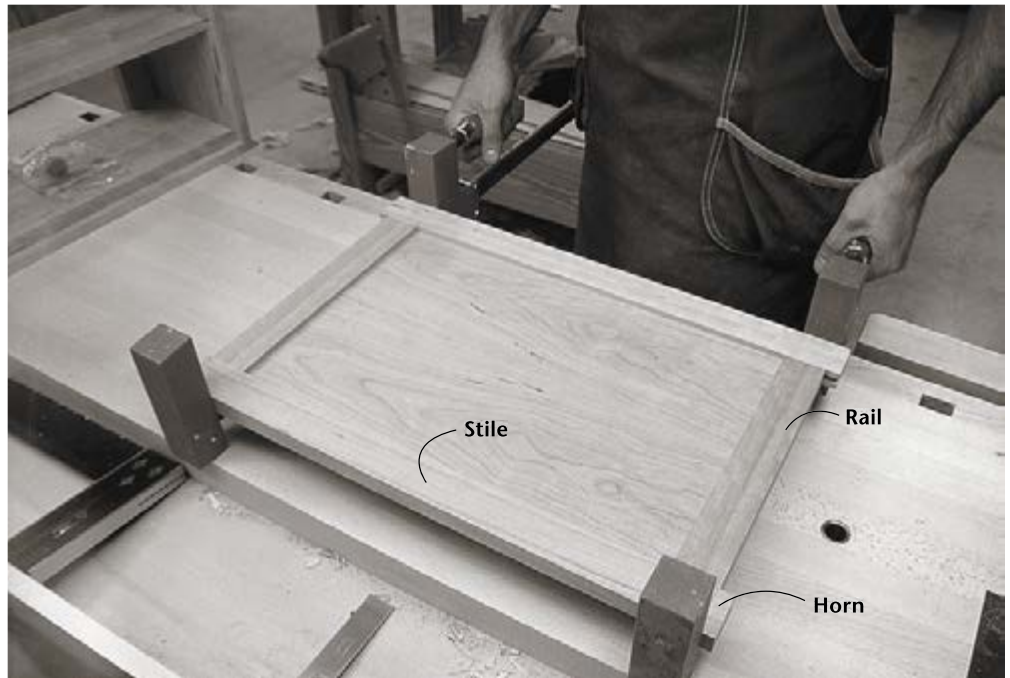

You can see here how the stiles stick out past the rails of the door. These are the so-called "horns," which you then trim off to make the door the perfect size.

A Better Hinge

Installing hinges for an inset door can be a brutal lesson in precision. Inset doors, as their name implies, sit inside the cabinet or the cabinet's face frame. The space between the door and the cabinet – called the "reveal" – has to be perfectly equal all the way around the door or it won't look right. Overlay doors, on the other hand, are much more forgiving to install because a rabbeted lip on the door

covers up the gap between the cabinet and the door. If you're a little off – or sometimes even a lot – no one will ever notice. But overlay doors don't generally have the look of a fine and refined piece of furniture. They say "kitchen cabinet" instead of "prized possession."

So if you want to install inset doors, you're going to have to wrestle with mortising a butt

hinge into both your cabinet and door, right? Wrong. During the last five years we have become huge fans of a hinge made by Amerock that is remarkable for three reasons: One, it lets you install the hinge without cutting a mortise. Two, once you install the hinge you can tweak its position until the door is perfect and then lock in your final setting. And three, these hinges look great on traditional cabinets.

The secret to these remarkable hinges is that they have oval-shaped holes for screws that allow you to shift the door slightly up and down in its opening and even cock it deliberately out of square to match a door opening that's not perfect. Once you get the door just right, you secure the hinge permanently with either a final screw or a brad – depending if the hinge is designed for a face-frame cabinet (which uses what Amerock calls a "full back-to-back wrap-around hinge") or a frameless cabinet (which uses a "partial wrap-around hinge").

In the hinge pictured at left, you can see the holes for the brads in

the leaf that attaches to the case. Curiously, you have to supply your own brads to lock this leaf in place; my only gripe with this hinge is that they aren't included.

On the leaf that attaches to the door you can see the two screw holes that lock in that setting. (One of the holes has a screw in it; the other does not.)

The Amerock hinges are available in a variety of finishes, including wrought iron, brushed nickel, dark antique brass, antique brass and polished brass. Plus they are available in a variety of styles that match many styles of furniture with a finial tip, a ball tip or just a plain button. These hinges aren't cheap – about \$6 per pair no matter where you go. But that price includes high-quality screws for installing them. Once you try these hinges, we don't think you'll go back to traditional mortise hinges unless you have to. **WM**

– Christopher Schwarz

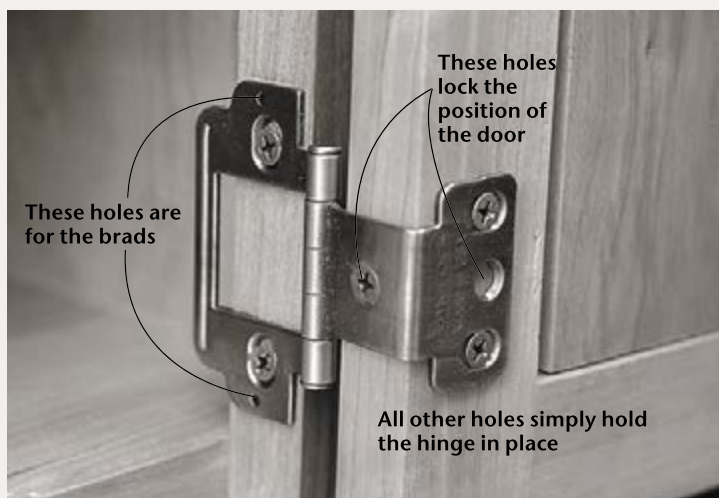

If you struggle with installing hinges for inset doors, this can make it easier.

Amerock Corporation
4000 Auburn Street, P.O. Box 7018,
Rockford, IL 61125-7018,
800-435-6959 or amerock.com

correct length. Test the fit in the door's opening and fine-tune things until the door has a perfectly consistent gap all around. You can use a table saw to do this, but I prefer a hand plane because I mess things up in a much slower fashion than with a power tool. Once your door fits, you can tweak its position in its opening if you use the hinges we recommend in the Supplies box below. Add the knob of your choice and a catch (the magnetic ones are the easiest to install).

More Notches in Your Back

As I designed this project, I tried different ways to make it so the back was not one piece of 17½"-wide solid wood. The solutions were more complex than I liked or they didn't look right, so I decided to stick with the original wide back.

To make this work, I first had to calculate how much the back would expand and contract in a typical Midwestern environment (which has some pretty radical humidity fluctuations, I can tell you). Using the formulas in R. Bruce Hoadley's "Understanding Wood" (Taunton Press), I figured out how much movement to expect. According to Hoadley's formulas, the panel will expand about ⅛" when the humidity fluctuates between 8 percent and 14 percent. This is a reasonable range to expect in our climate.

So now you need to measure the space between the two rabbets on the backside of your assembled carcass. It should measure 17". So the lower part of the back piece should measure 16⅞" wide. That's simple enough. The real difficulty comes when dealing with the curvy top part of the back. It's 17½" wide. That extra width overhangs the top of the cabinet. Once again this means you have to create a stopped notch on the two long edges of the back.

The simplest procedure is to use the same trick you used for creating the notch on the top piece: Gluing small pieces on the back to make a notch. And that's a fine way to do it as long as you pay close attention to matching the grain. This is a very visible part of the cabinet.

Make your back piece a bit wider to start with: 18" is about right. Rip two strips off each long edge so the back ends up 16⅞" wide. Keep track of which edge each strip came from because that will make it easier to match the grain when regluing the blocks in place. Now take those narrow strips and crosscut 5" off the top of each. Reglue these blocks to the back.

After the glue dries, mark the curvy shape on the back and cut to that line. A band saw, scroll saw or coping saw will do. Just make sure it's a fine-tooth blade. Clean up the rough saw-cut edges with sandpaper, files or a spokeshave. Then drill the 1¼"-diameter hanging hole in the location shown in the drawing. Finish-sand your back.

Attaching the back is easy if you pay attention to the issue of wood movement. The back

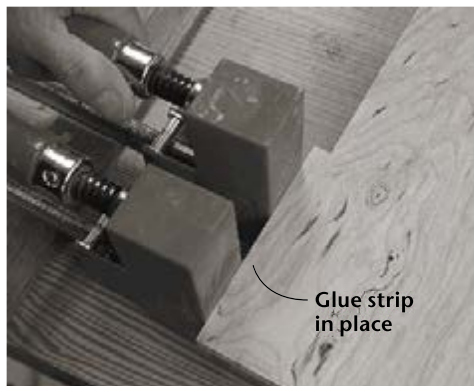

To make this notching operation go smoothly, make sure you rip the narrow strips from the back using a sharp rip blade. This will ensure that you'll get a clean cut and the blocks will be easier to reglue and get a seamless joint.

is attached by screwing through it into the top and bottom pieces. You want to secure the back in the center of the cabinet so it expands equally on either side. Here's how to do that: Drill six screw holes in the back, three along the top and three along the bottom. The middle hole should be a standard round clearance hole. But the holes to the left and right should be elongated left-to-right. It's these elongated holes that allow the back to expand and contract with changes in humidity.

I've seen people make a template to rout perfect elongated ovals. Then they make the countersink using a template and a chamfer bit. This is not necessary. All you really need to worry about is allowing the shaft of the screw to pivot as the back moves. The screw's head can remain basically in the same place.

Here's how I make elongated holes: Drill a standard clearance hole for your screw that allows the screw's shaft and threads to pass through without biting into the wood. Next, angle your drill 45° one way and drill out a bit of one side of your clearance hole. Then angle the drill 45° the other way and drill out the other side of your hole. Finally, come back with your countersinking bit and countersink your clearance hole. Once done, then you can screw the back to the case using some #8 x 1"-long screws.

Finishing Cherry

Before you apply a finish to this project, take a few minutes to break the sharp edges with #120-grit sandpaper. This will make your project more enjoyable to touch and less likely to get damaged. Now remove the back and door.

Because cherry darkens nicely with age, I prefer not to add much coloring. In any case, staining cherry can be difficult because it blotches.

But new cherry with a clear finish looks a bit anemic until it gets a couple of years of coloring, so I like to help the process along. Begin



This elongated hole allows the back to expand and contract and still stay tightly secured under the screw. I make these holes by wiggling my drill bit. The other option is to drill a round hole and elongate it with a small rat-tail file.

by wiping on a coat of boiled linseed oil that's thinned down to a water-like consistency with paint thinner. Wait about 30 minutes and wipe off the excess. Then take your project outside and let it bask in the warm sun for an afternoon or two. This will jump-start the coloring process.

After a couple of days of letting the oil cure, you can add a protective top coat. The simplest finish for this is a wiping varnish – essentially a thinned-down off-the-shelf varnish. For more details on mixing and using this finish, check out "Understanding Wipe-on Finishes" on page 30.

If you want to hang this project like the Shakers did, you'll need to build and hang a board with Shaker-style pegs. The length of the board is up to you and the scale of your room. We've included a supplier of cherry Shaker pegs below.

The last trick is to find a place in your home that really shows off the proportions and workmanship of this fine piece. You don't want this project to ever languish in the background. **WM**

Contact the author at 513-531-2690 ext. 1407 or chris.schwarz@fwpubs.com.

Supplies

Rockler

800-279-4441 or rockler.com

2 ■ Amerock ball-tip, full wrap-around hinges in antique brass, #31300, \$5.99/pair

1 ■ Cherry Shaker 7/8" knob, 3/8" tenon, #78493, \$2.59/pair. (Also available in oak, walnut and maple.)

1 ■ Narrow magnetic catch, #26559, \$1.49 each

■ Cherry classic Shaker pegs, #23382, package of eight/\$6.48 (Also available in oak and maple.)

Prices correct at time of publication.

Shelf Support Basics

Storage doesn't do you much good if you can't divide it to suit your needs. That's what shelving is all about and there are a number of ways to put your shelves in just the right position. We've gathered the best of the pack here with quick explanations of their best applications.

Though there are a number of good choices listed, the most common support with the best price and function is the spoon pin, with or without the sleeve. We also appreciate the invisible application found

with either the low-profile pin or the hidden shelf wire. When using any of the supports that require carefully located holes in your cabinet sides, we recommend cutting a piece of 1/4" hardboard or plywood to about 3" wide and nearly the height of your opening. Drill a single line of shelf holes in this piece and use it as a template for all the holes. **WM**

– David Thiel

Standard with Clip

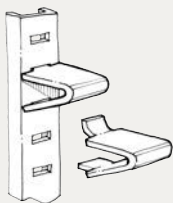

One of the most common, inexpensive, versatile and ugliest shelf supports ever manufactured. While you can easily adjust shelf locations in 1" increments, the metal track is always visible and requires a groove machined in the sides. This support looks best in office furniture – not a project you spent hours building. Available in ugly nickel or zinc plate, ugly white and uglier brown.

Reinforced Support

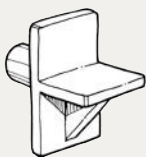

An economical option, this plastic support slips into a hole (or multiple holes to allow for adjustment) that you drill in the cabinet sides. Like the metal track above, these are also common in office furniture and are not attractive. They also hold the shelf away from the side by as much as 1/8".

Locking Support

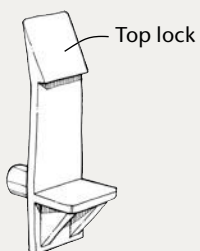

This support also fits into holes drilled in the cabinet sides. As an added feature, it locks the shelf in place from above, avoiding accidental tipping. Economical, but still rather unsightly, it also holds the shelf away from the cabinet sides. Use this for commercial furniture or for shop cabinets where you don't want a shelf to ever come crashing down – not for that Queen Anne highboy.

Right-angle Support

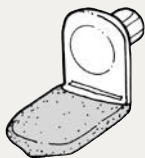

Slightly less unsightly, this support is almost invisible (with the shelf in place). The optional rubber pad keeps the shelf from sliding off, but it still leaves an unattractive gap between the cabinet side and each shelf. This is a good choice for furniture in a child's room or in a rumpus room.

Adjustable Support

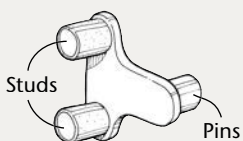

This support compensates for sloppy drilling. By trapping the shelf between the studs, the pin can rotate in the hole to find a balance between the four holes. A nice feature, but the ugly gap is still there, and now you've got a stud showing above the shelf. Save this support as a last option if (or when) you've messed things up.

Straight Pin

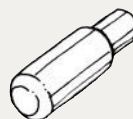

This is a true pin. Although low visibility, it has some problems. If the hole is slightly oversized, the pin can work loose, dumping the shelf. If the holes are not drilled perfectly, the shelf will wobble. On the other hand, if small notches are cut on the underside of the shelf, the pin can nestle in the notch, holding the shelf firmly.

Spoon Pin

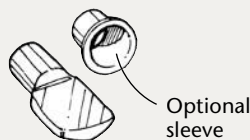

A refined version of the straight pin, this pin can be used with or without the sleeve. It's then slipped into a hole or holes drilled in the cabinet side. The pin allows the shelf to fit all the way against the cabinet side without any visible gap, but still has a shoulder to hold the shelf in place.

Screw-in Spoon Pin

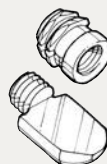

Taking the pin and sleeve concept a bit further, this pin screws into its sleeve. It's a nice idea, but ultimately a little like gilding the lily, and best reserved for high-end glass casework. These pins are pretty darn expensive because you have to buy a threaded sleeve for every shelf-pin hole.

Low-profile Pin



The most invisible and still very economical, this support requires a little extra machining. The plastic pins are still slipped into holes drilled in the cabinet sides, but the shelves themselves have stopped saw kerfs along the ends that accept the blade of the pin. The shelf fits around the pins (in place) and the support disappears.

Hidden Shelf Wire

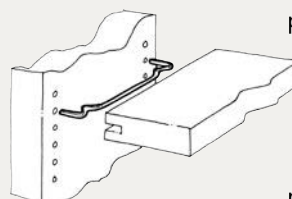

Another invisible variation is a hidden shelf wire. Rather than using two independent pins that slip into grooves in the shelves, this system uses a wire support. Essentially requiring the same amount of machining and drilling, this actually provides a more stable support and puts less stress on the shelf. The wire spreads the support over the depth of the shelf rather than focusing it on two bearing points.

Smart Ways to Hang Cabinets

Once you've completed the Shaker Hanging Cabinet, you can sit back and enjoy it. Well, almost. You still need to hang the cabinet – and it's been our experience that this final step can take minutes or hours, depending on your planning.

The hanging process should actually begin with the design phase of the project. With the cabinet shown here, we've followed the Shaker tradition and mounted a peg board to the wall, with the cabinet hung from a peg.

Other methods (more common today) are to mount the cabinet to the wall through the back of the cabinet (either with just the back or with a hanging strip) or to use a French cleat, which is invisible and convenient.

Screwing Through the Back

Depending on the size of your cabinet, you may have used a 1/4"-thick back or thicker (1/2" or 3/4"). With a thicker back, mounting the hanging cabinet to the wall is simply a matter of finding a stud and marking that stud location on the inside of the cabinet. Then you drill a clearance hole for the screw (usually 3/16" diameter), hold the cabinet in place and level on the wall, and screw the cabinet to the stud with a #10 x 3"-long screw. If the cabinet is wider than 16", you'll be able to put a second screw through the back and into a second stud. This should be enough to support most cabinets that aren't going to be holding your grandmother's fine China.

If your cabinet is less than 16" wide, you'll need a drywall "molly" to reinforce the second screw. Mollys are sold in the picture-

hanging section of your local hardware store and allow you to put a screw almost anywhere in a wall. There are half a dozen different kinds of mollys that are suited to hold different weights. Check with your local hardware store for a good selection.

If you're hanging a large cabinet and want to use a 1/4"-thick back (to make it less expensive and lighter in weight), a hanging strip will make mounting the cabinet easier. This strip (shown below left) can be built into the design of the cabinet or simply applied to the back. It goes inside the cabinet and below the top. Actually building the strip into the sides adds some strength, but it also adds an extra step or two to the project.

Screwing through this strip instead of just the thin back will give you more strength and reduces the chance of tearing through the thin back material with the screw.

Using a French Cleat

French cleats offer invisibility and incredible strength, but they do steal some storage space from the inside of the cabinet. These cleats can be purchased (made from aluminum or steel) for the truly lazy, or made from simple 3/4"- or 1/2"-thick scrap. The cleat is in two pieces, each with a 45° bevel on one long edge. One goes on the back of the cabinet; the other attaches to the wall. When you nest the 45° bevels together, the cabinet hangs firmly on the wall. You should be able to do pull-ups on your cabinet if it is properly installed this way – no kidding.

To use a French cleat, you have to design a

gap behind the back of the cabinet to house it. Essentially the cabinet is built with the back recessed into the cabinet, so the top, sides and bottom still touch the wall.

Beyond the strength gained by using a cleat (as long as you catch a stud or use mollys), cleats are easy to level. The wall section of the cleat is attached with one screw and that section is leveled and fixed in place. Then the cabinet is simply slipped in place over the wall cleat. It's pretty cool. **WM**

— David Thiel

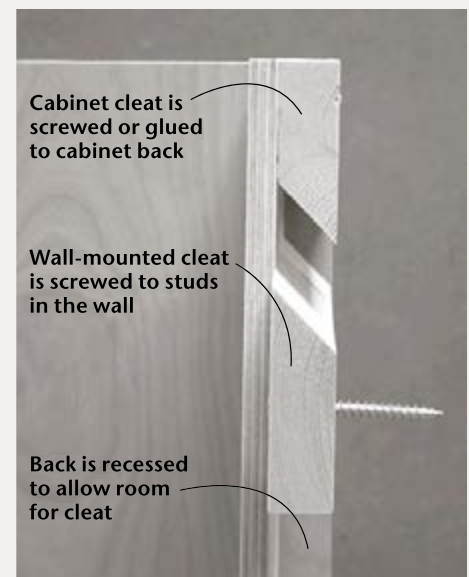

The shop-made French cleat in action. This French cleat is made for a board ripped at a 45° angle, but the cleat also could be made with interlocking rabbets. Either way, you get some amazing strength and convenience.

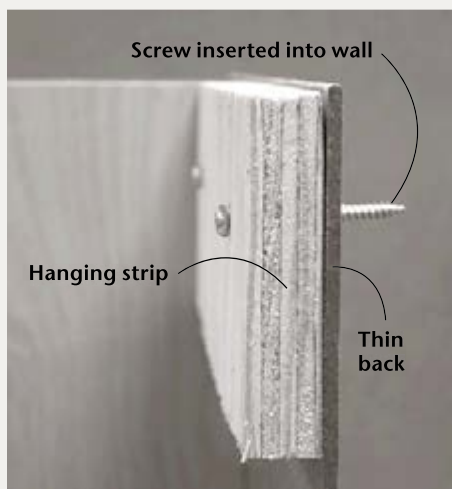

With a larger cabinet, a thin back makes more sense but will not be sufficient to secure the cabinet to the wall. By adding a hanging strip, the weight of the cabinet is more evenly transferred to the cabinet box.

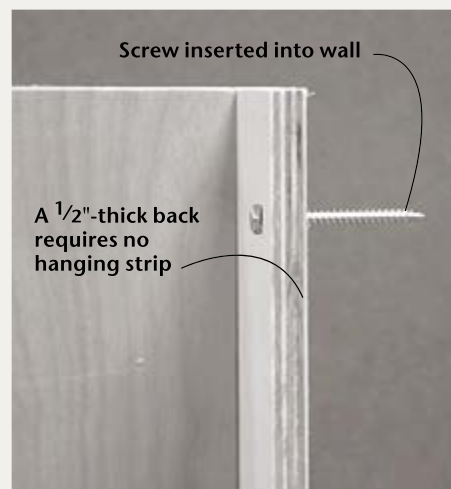

With smaller cabinets, a thicker back (usually 1/2" or more) can be used without any major weight concern. This thicker back also allows you to simply screw through the back of the cabinet directly into the wall and stud.

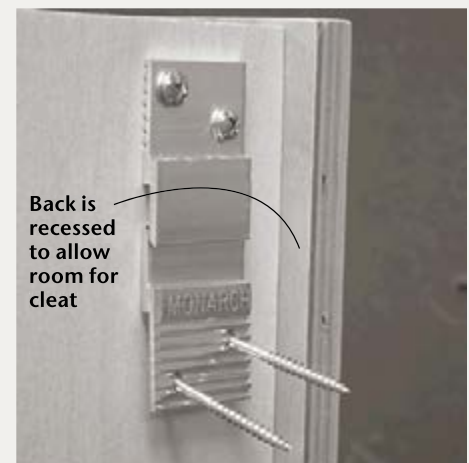

This store-bought version of a French cleat takes up less room behind the cabinet and is priced at about \$13 for 10 sets. Place one hanger every foot to hold heavy cabinets.

Enfield Shaker Cabinet

Casework built with dados and glue alone is troubling. We uncover one old-school solution that ensures your work will endure real life.

Building reproductions of antiques can be like unraveling a mystery. This cabinet from the small Shaker community in Enfield, Conn., has yet to reveal all its secrets. For one, I'm not entirely sure what it was used for at the colony. A couple places refer to it as a jelly cupboard, but most sources prefer the following less-than-helpful label: pine cabinet.

But here's what we do know about the piece and where it comes from. The cabinet was built in the first half of the 19th century (some sources cite circa 1830) at the Enfield colony for the use of its members. Unlike other colonies, some sources state that the Enfield Shakers did not produce furniture for sale to the outside world (although some sources claim they did). Instead, the residents at Connecticut's only Shaker colony ran a thriving seed business. (Shakers are credited with the innovation of selling seeds in envelopes.)

Enfield was founded in 1782, hit its membership peak in 1855 with about 200 members, and then declined like all the other Shaker colonies – with the last eight survivors selling the land and retreating to other remaining colonies.

The cabinet passed into the hands of Edward Deming Andrews and Faith Andrews – two of



When people first see this cabinet, their instinct is to call it a jelly cupboard, chimney cupboard or pie safe. We're not so sure what its original purpose was, but it does have nice lines.

the most influential collectors and chroniclers of the Shakers. Sometime in the 20th century, the cabinet passed through the workshop of Ejner Handberg, a Massachusetts cabinetmaker who repaired and restored a number of pieces from the Andrews collection. While these original pieces were in Handberg's shop, he made full-size drawings of them on cardboard he scavenged from refrigerator and stove boxes.

Those drawings became "Shop Drawings of Shaker Furniture and Woodenware" (Berkshire House), three volumes of books that are illuminating and frustrating. They're illuminating because they're one of the few sources of measured drawings of Shaker originals. And they're frustrating because some specific construction details aren't present. So the books, which I still recommend highly, leave me with many questions.

A Joinery Problem

One area that concerned me with the cabinet was the joinery as drawn. The shelves are housed in dados in the sides. This is a well-accepted way to build a cabinet, but it has always troubled me.

If you think about it for a minute, the dado joint is a poor glue joint in solid wood. Every mating surface in a dado joint puts a long-grain surface against an end-grain surface. In other words, chances are your dado joints are going to be weak because the end grain in the shelf and sides is going to soak up the glue and starve your joint. If the glue weakens and fails, the cabinet will be held together by the glued-on face frame (don't forget that the glue could fail there, too, if stressed or wracked) and the back of the cabinet. If you use a solid-wood shiplapped back, that's not going to offer much support compared to a screwed-in plywood back.

So if you're a woodworker who is concerned about the long-term survivability of your furniture, dados alone might not be a good option. But what do you do?

Avoiding the Overly Fussy

The logical solution would seem to be the sliding dovetail. It's an all-wood mechanical joint that will hold forever, even without glue. But have you ever tried cutting and fitting a whole case of these with 13"-wide shelves? How about 20"-wide shelves? It's a challenge. If you cut the joint square and tight-fitting, it won't go together because of the friction involved. So you have to tweak the male part of the joint to make it sloppy. But how sloppy? And how do you make it perfectly sloppy reliably and repeatedly? Personally, I've found the sliding dovetail better suited for joining smaller widths – think 3"-wide drawer dividers at the front of a chest of drawers.

Instead, I've come to rely on dados that are reinforced by a mechanical fastener – usually a nail but sometimes a screw (think pocket screws). There's a snobbery in woodworking that nails are low-class wood-butchery. Don't believe it. If you've inspected much antique furniture, you'll find nails used extensively. But you have to look close. Though the nails might be easily spotted in mouldings and carcass backs, some of the others are harder to find. Look inside a piece and you might find nails that toenail the shelves or drawer runners to the sides. Lots of the interior guts of a piece can be (and were) nailed. It's a fast way to build. The nails will be there if the glue gives way. And the correct nail will wedge the joint tight for decades, maybe centuries. For a complete discussion of the right nails and classic toenailing techniques, see "Build Furniture With a Hammer" on page 12 in this issue.

A survey of Shaker pieces in books and in person reveals that they also used nails in their furniture – sometimes hidden and sometimes not. So even though Handberg's book doesn't show a



I always prefer to have my router template below my work whenever possible. This allows me to use a pattern-routing bit with the bearing on the bottom and limits the amount of spinning carbide exposed to the area below my waist.

single nail in his drawing of this cabinet, I took a leap of faith and decided to use both glue and nails in construction. I also took other small liberties. I used cherry instead of pine and made the mouldings easier to fabricate and attach. To ease assembly I also tweaked the back so it's visible at the top of the cabinet. These are but minor sins. When I compare my versions of this cabinet to Smithsonian photographs of the original, I know that I got this one right.

Sides and Feet

Because 13"-wide cherry boards are uncommon, you're likely going to have to glue up at least a couple boards edge-to-edge to make the side panels. You should of course pay close attention to the grain at the mating joint in the middle of the panel – try to match the grain patterns so that the joint becomes almost invisible. One good strategy here is to try to find some 9'-long boards, crosscut them in half and join them edge-to-edge



Accurately paring this corner is easy if you do it right. First score the end grain of the waste with your chisel, then come back and pare it out to your lines. Place the chisel flat against the flat section of your foot's shape. This guides the tool for a perfect cut – and is why chisels need their unbeveled face to be truly flat.

to make a single side piece. Usually the grain and color are easier to match up when the two pieces come from the same board.

But there's another detail to watch. As you prepare your panels for glue-up, also pick out the wood for the face frame. Do your best to match the grain where the sides meet the face frame stiles. This is a highly visible part of the cabinet and a poor grain or color match will be jarring.

After you've glued up the side panels, glue up the panels for the shelves. This is where you can use your knotty, sappy odd-looking stuff with abandon. Just make sure the front edge of each shelf looks good – that's all anyone will ever notice. Trim your sides and face frame stiles to size and then prepare your router templates that will be used for the feet.

Make the template from 1/2"-thick plywood, trace the shape on your sides and cut about 1/16"

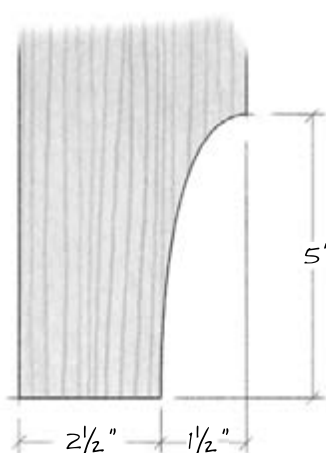

FRONT LEG DETAIL

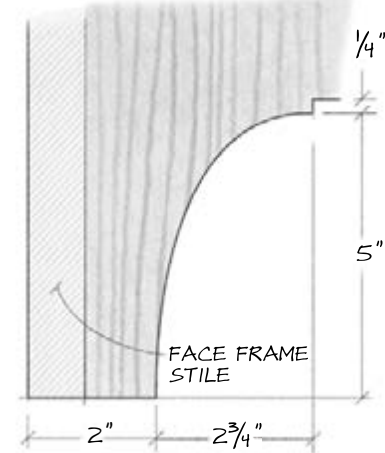

SIDE LEG DETAIL



The right-angle dado guide here was designed specifically for 1/2"-wide dados. Make the jig large enough to clamp it easily to your work and bench without interfering with the router or your hands. When building this jig, be sure to consider the clamping job ahead.

shy of that line with your band saw. Then follow up by routing the shape with a router. You could clean up your saw cuts with hand tools, such as rasps, files and a spokeshave. But because there is so much end grain in this shape, the router is the superior choice if you have the equipment.

If you go the router route, you'll have to clean up the step between the curve and the flat section of the shape – the router will leave a rounded corner. This is quick work for a wide chisel.

The next step is to cut the dados in the sides. There are two paths to follow here. You could rout 3/4"-wide x 1/4"-deep dados and fit the shelves into these by tweaking the thickness of the shelves with a bench plane until you get a good fit. The other alternative is to cut 1/2"-wide x 1/4"-deep dados and then cut a 1/4" x 1/4" rabbet in the ends of each shelf. Then you can tweak the fit of the shelf with a shoulder plane or bullnose rabbet plane by planing the rabbet on the shelf – rather than the entire shelf.

I built one of these cabinets with the wider dados and one with the narrow dados. There is little difference between the two approaches. With the wider dados there was less joinery involved, but you have to be careful when sizing each shelf to fit. It's easy to overshoot and get an ugly gap and a loose fit between the shelf and side. With the narrow dados, you have more joinery setups to deal with, but even if you overshoot the mark when fitting your shelf, you won't create that gap because the shoulder of the rabbet will hide it. Either way is fine; pick one that appeals to your skills and the tools at hand.

I milled the dados with a router, straight bit and a shop-made right-angle guide. We covered this process in great detail in Issue 3 of *Woodworking Magazine*. One detail worth mentioning: I milled the dados before milling the rabbet for the backs. This was on purpose. When you mill dados with a router, you will usually get some grain blow-out when the bit exits the work. Cut-



Install enough dado cutters on your table saw's arbor to make a cut that is slightly wider than 3/4". Then clamp a zero-clearance auxiliary fence to your fence as shown. The key to an accurate rabbet with this method is to keep the work pressed firmly to the saw's table during the cut. The dado stack will try to lift it off the table. For added insurance, repeat your pass on the part to make sure you have a rabbet of consistent depth.

ting the rabbet after the dados will clean up any blow-out on your back edge.

The 3/4"-wide x 1/4"-deep rabbet at the top of the case sides can be cut in two passes – both cuts guided by the right-angle guide.

Now cut the 3/4"-wide x 1/2"-deep rabbet on the inside back edge of both sides. Cutting big rabbets is a task best suited for a dado stack in a table saw, a conclusion we reached after cutting dozens and dozens of rabbets for Issue 1. The zero-clearance auxiliary fence shown in the photo above is a must for this operation.

I clean up my rabbets with a shoulder plane after cutting them with a dado stack. Is this neces-

sary? Perhaps not – this rabbet for the back will not be a glue joint. But a couple passes with a shoulder plane ensure that the corner of the joint is clean, which ensures the back will fit tight.

With the joinery in the sides complete, plane or sand the interior face of the side pieces to prepare them for finishing. Planing and sanding reduces the thickness slightly, so you should do this before fitting the shelves. If you plane after you fit the shelves, that can loosen your joinery.

Fitting Shelves

Now you should turn to fitting your shelves in your dados. If you've opted for the narrow dados, you'll need to mill mating rabbets in the shelves – use the dado stack already in your table saw. You'll have to adjust the settings for a good fit.

After cutting the rabbets, clean them up and tweak their dimensions so that each shelf fits in its dado. Each shelf might need a different number of passes to fit. Don't be alarmed by this. The rabbet on your shelf could be a little off because you didn't use as much downward pressure when cutting it on the table saw. Or perhaps your stock is cupped slightly. That's what the shoulder plane is for – it can correct a great number of ills that some people would try to fix with a mallet.

If you own a narrow shoulder plane or router plane that can fit into the width of the dado, it's a good idea to clean up the bottom of the trench. A smooth bottom will glue better. And this joint needs all the help it can get.

If you opted to make the carcass with the wider dados, use a plane set for a fine cut to tweak the thickness of the shelf until it seats firmly in the dado. When I go down this path, I rely on my dial caliper to speed the work and make it pre-

Enfield Shaker Cabinet

NO.	PART	SIZES (INCHES)			MATERIAL	NOTES (DIMS IN INCHES)
		T	W	L		
Carcass						
<input type="checkbox"/>	2	Sides	3/4	13 3/4	51 1/4	Cherry
<input type="checkbox"/>	5	Shelves	3/4	13	19	Cherry in 1/4"-d. dados & rabbet
<input type="checkbox"/>	2	Face frame stiles	3/4	4	51 1/4	Cherry
<input type="checkbox"/>	1	Face frame rail	3/4	2 1/2	14 1/2	Cherry 1 1/4"-l. tenons, both ends
<input type="checkbox"/>		Backboards	3/4	19 1/2	45 1/2	Cherry shiplapped, beaded
<input type="checkbox"/>		Top cap moulding	3/4	1 7/8	60	Cherry 1/2 x 1/2 rabbet, 3/16"-r. astragal
<input type="checkbox"/>		Cove moulding	3/4	7/8	60	Cherry 5/8"-r. cove
<input type="checkbox"/>		Astragal moulding	3/8	3/8	60	Cherry 1/8"-r. astragal
Door						
<input type="checkbox"/>	2	Door stiles	3/4	2 3/4	43	Cherry
<input type="checkbox"/>	1	Top rail	3/4	3	9	Cherry 1 1/4"-l. tenons, both ends
<input type="checkbox"/>	1	Middle rail	3/4	5	9	Cherry 1 1/4"-l. tenons, both ends
<input type="checkbox"/>	1	Lower rail	3/4	4	9	Cherry 1 1/4"-l. tenons, both ends
<input type="checkbox"/>	2	Panels	5/8	7 1/4	16 1/4	Cherry 3/8"-t. x 1/2"-l. tongue, all edges
<input type="checkbox"/>	1	Door stay	3/8	3/4	1 5/8	Cherry 5/16" wedged dowel as pivot

TOP
VIEW

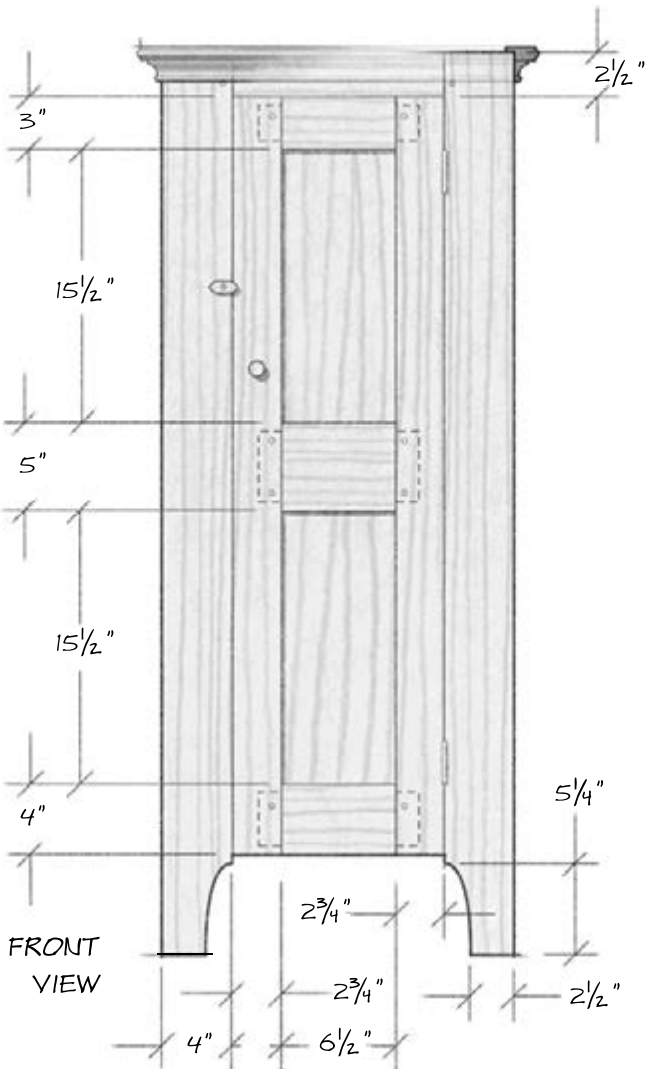
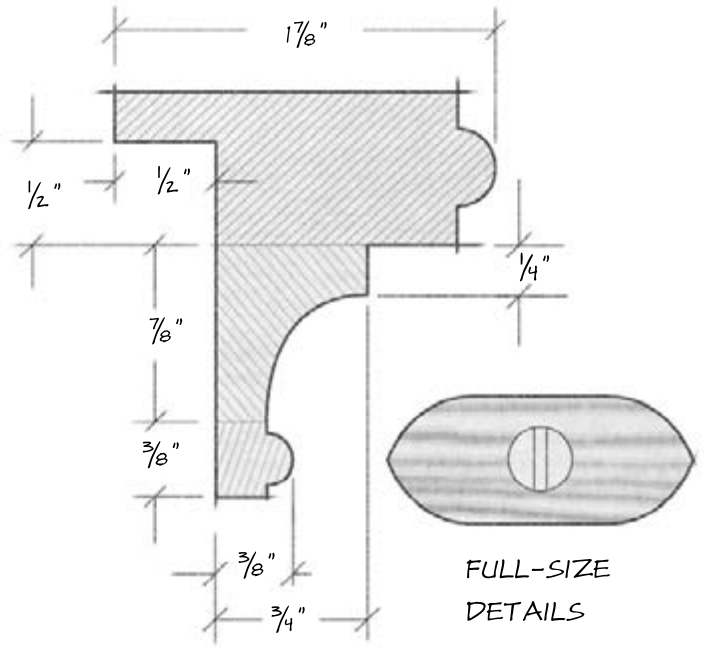
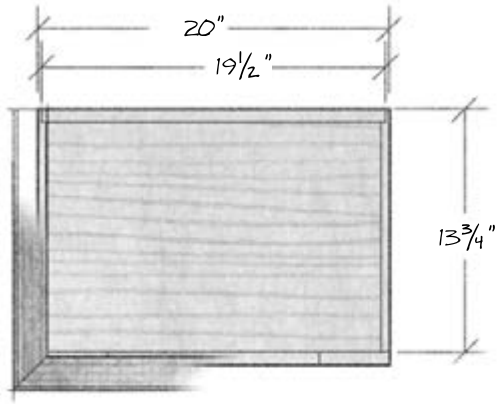

FRONT
VIEW

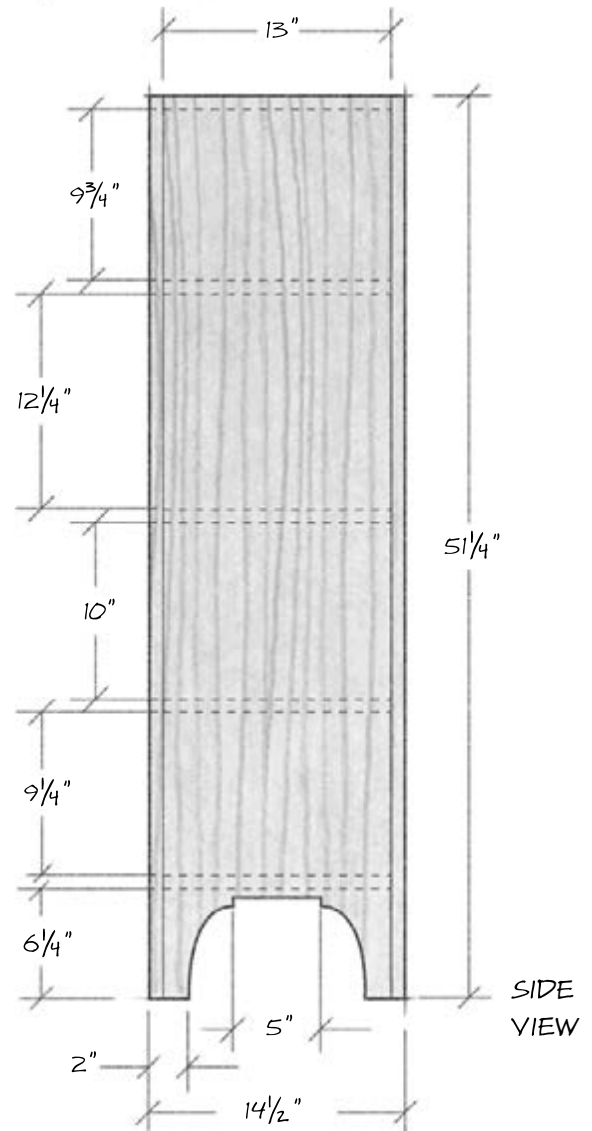

SIDE
VIEW

ENFIELD SHAKER CABINET



A gimlet has myriad advantages when making pilot holes for nails. There's no chuck or drill body to interfere or strike your cheater block. And it gets into tight places that no drill can go. Note that the hole and nail are installed at an angle – mine slope toward the center of the side panels by 7° or so – like a dovetail. This increases the wedging action of the nails.

dictable. Use your dial caliper to measure three things (this is when you should use its decimal function). Measure the width of the dado. Measure the thickness of your shelf. Then measure the thickness of a shaving from your plane. Now you know approximately how many passes you'll need to make with your bench plane. Here's a typical example: My dado is .750" wide. My shelf is .756" thick. And my plane is set to take a .001"-thick shaving. So I know that if I take three passes with my plane on each face of the shelf I will be close to a close fit.

I know this sounds fussy, but it is surprisingly fast and easy to do. And it works – I've been doing it for years. Plus, once you make your three passes with your plane, the surface is ready for assembly and finishing.

Once everything fits, clamp up the project without glue. Then take everything apart and reassemble it with glue. Although this isn't a particularly complex assembly, I would choose a slow-setting glue (Such as Titebond Extend) or perhaps a liquid hide glue (such as Old Brown Glue), which is both slow-setting and reversible

"My eyes have been filled with the endlessly changing patterns of the grains. I have felt the warmth of a thousand suns in my hands every day. I have smelled the rich, tangy odors of the freshly benn chips. These are the things that have made my life so fine. These are the most precious things I can leave for you, my son."

— Jonas Wainwright, carpenter
from a letter to his son in 1832



When toenailing, you quickly run out of room for your hammer's head and need to turn to the nail set to finish the job. Resist the temptation to strike the nail head at an angle in lieu of the nail set. The nail will usually bend.

with heat and water. You also could use a polyurethane glue, which sets slowly, but there can be some foamy squeeze-out problems if you're not an experienced user of this adhesive.

Toenailing for Tenacity

Once the glue has cured and you can take the project out of its clamps, toenail the shelves to the sides using cut nails. All cut nails require a pilot hole, and these cut fine finish nails require a $\frac{3}{32}$ " pilot to ensure the wood won't split during nailing. I have a little cheater block shown in the photo above that guides my pilot bit. This little block guides my gimlet at the correct angle. A piece of tape on the gimlet indicates when I should stop turning. To make your own cheater block, simply draw on your project the path you want your nail to take through the shelf and side. Transfer that angle to a piece of scrap and cut the scrap to that line. There's no science to it. My cheater block starts the pilot hole $\frac{1}{4}$ " up from the inside corner and at a 35° angle.

Installing cut nails is straightforward. Start the nail with the cross pane (if your hammer has one). Cut nails will sometimes twist in their holes. If they twist too much, they'll split the work. A cross pane helps you keep the nail oriented correctly as you start it. Then sink the nail as deeply as you dare with the face. Finally, sink the nail $\frac{1}{8}$ " below the surface of the wood with a nail set.

Place a nail at each corner where the shelves meet the sides. But don't toenail the top in place. Because that area of the sides will be covered by moulding you can nail the top in place from the outside of the case. This also adds to the overall strength of the case. Note that the nails on the outside of the case should be angled, much like dovetails, to increase their wedging power.

An Unusual Face Frame

The face frame for this cabinet has two stiles and one top rail – no bottom rail. This configuration makes it easier to assemble the face frame but more challenging to install. All of the joinery for the face frame is the same as the joinery for the



When installing cut nails, do what you can to keep them away from the ends of the board. Cut nails are little wedges and if they are installed too close to the end, they will split the work. These are installed $\frac{3}{8}$ " in from the end. I used four nails in each side.

door, so you should cut everything at the same time. One word of advice: Cut the stiles for the door and face frame $\frac{1}{16}$ " wider than the finished width. This will give you some room to trim the face frame flush to the carcass after assembly and extra meat to trim the door to width.

If you are going to mill the mortises in the stiles by machine – a drill press or hollow-chisel mortiser – then I recommend you make the mortises $\frac{3}{8}$ " wide and the tenons a matching $\frac{3}{8}$ " thick. The $\frac{3}{8}$ " mortising chisel removes waste very effectively. If, however, you are going to mortise these by hand, I recommend a $\frac{1}{4}$ "-wide mortise – your mortising chisel will be less likely to destroy your work during the sometimes-brutal mortising process. There are many ways to cut mortises by hand, and I've been experimenting with five methods (some ancient; some mod-



If you mill your mortises by machine, use a $\frac{3}{8}$ " hollow mortise chisel, as shown above. Be sure to skip a space between each plunge on your first pass. Then come back and clean up the waste between the square holes. This prevents damage to your tooling.

ern) for several months now for a future issue. I haven't reached an ultimate conclusion, but I right now am favoring an approach where you drill a hole at one end of the mortise and then pop out the waste by angling the chisel toward the hole. You can see this technique in action at Jeff Gorman's website (go to amgron.clara.net and click on "Mortising and Tenoning").

For cutting the tenons, you have many choices. You can saw them by hand or mill them using a router – both techniques were covered in Issue 2. A third option is to use your table saw and a dado stack in a manner similar to that described with a router table. I chose the table saw for this project to keep the number of tooling setups to a minimum – the table saw was already set up for this operation from the previous two operations.

And though there is but one rail in the face frame, make an extra rail and cut the tenons on it as well. During assembly you can clamp this extra rail between the stiles at the foot to keep your face frame square.

I recommend you make your tenons 1 1/4" long. This length will allow you to successfully drawbore the joint, a technique explored in Issue 4. If you have no wish to drawbore the joint you can drive a peg through the joint after assembly to achieve the same look – but not the same mechanical integration. Now plane or sand your face frame parts and assemble the frame. Drawbore the joints or peg them after assembly. I used a 3/16"-diameter peg.

Glue the face frame to the carcass and clamp the extra rail between the stiles as shown in the photo at right. The face frame should extend proud of the sides a bit, which is correct. I find it easier to prop up the project on low beams on my bench so I can clamp across the face frame and sides with the project lying on its back. Once the glue is dry, trim the face frame flush to the carcass. I prefer to use a bench plane for this operation, but an electric router equipped with a flush-trimming bit will also do the job. I prefer the bench plane because it will produce a surface ready for finishing – the router-cut surface will need sanding or planing.

Now you have a couple details to decide on. The original Enfield cabinet had a bead cut into the front edge of the frame. You can add this bead if you like. I milled a 1/8"-radius bead onto the second version of this cabinet I built (not the one on the cover). One nice aspect of the bead is it gives you a perfect trench on the face frame for nailing the face frame to the carcass.

Solid-wood Shiplapped Back

As mentioned earlier, a solid-wood shiplapped back is not going to add as much rigidity to your carcass as a plywood back. But it does look nicer every time you open the door of this piece.

You can make your backboards random or regular in width. Either way, you need to cut a



Cutting tenons on the table saw requires you to follow all the same protocols when cutting a rabbet. Keep firm downward pressure on the work – the dado stack wants to lift the work. Varying pressure will result in thicker tenons. Cut your face cheeks and face shoulder first.



Cut the edge cheeks and edge shoulders next. First raise the dado stack to make a 3/8"-deep cut. Then pass the work over the blades. Use consistent downward pressure when cutting tenons this way to ensure your joints are identical in their dimension. This makes fitting each joint easier.



Again, a slow-setting glue can be your friend in this situation. The joint between the face frame and carcass is highly visible. Clamp it until it looks tight all around.



The long edges of the stiles are easily trimmed flush with the carcass with a bench plane – it's soothing work, actually. However, trimming things up at the top of the cabinet is more of a challenge. There's a lot of end grain to deal with. Use a sharp low-angle block plane and wet the end grain with mineral spirits to soften the wood.



A D-handled router is designed for edge routing such as this. It adds stability and makes it easier to get a superior cut. Another option is to cut this bead with a moulding plane (side-bead planes are fairly common on the used-tool circuit). Those are next on my (long) list of hand planes to buy.



I used 8d headless cut brads to attach the face frame. Unlike the other brads in this project, these require a 1/16" pilot hole. The nail set drives the brad's head below the bead and out of sight.

$\frac{1}{4}$ "-wide x $\frac{3}{8}$ "-deep rabbet on each long edge of your backboards so they overlap one another and hide any seasonal expansion and contraction. I again turned to my table saw with the still-set-up dado stack to do this job. With the rabbets cut, I planed all the backboards to prepare them for finishing. Then I used the $\frac{1}{8}$ "-radius beading bit in a router in my router table to mill a bead on the long edges.

Installing shiplapped backboards isn't hard. I used a shoulder plane to tweak the rabbets to get everything fitting tight. Then I attached the backboards one by one. The boards on the ends can be fastened to both the carcass sides and the shelves. But the boards between them should be fastened with a row of screws (or nails) down the center of each board only. If you attach a board with more than one row of screws, you are asking for a split when the wood starts to move (and it will). Don't forget to leave a small gap between the boards to allow for seasonal movement.

Doors: Building and Fitting

Almost all the joinery for your doors should be complete. All you need now is a groove for the panels and a mating rabbet on the panels. The mortises in the stiles allowed me to cut stopped grooves easily with the plough plane.

Make your groove match the width of your mortises. If you cut a $\frac{3}{8}$ "-wide mortise, cut a $\frac{3}{8}$ "-wide groove for the panels. Now cut a mating rabbet on your panels. Use your table saw and dado set (again) to cut this $\frac{3}{8}$ "-deep joint. Fine-tune the results with a shoulder plane.

One fine point about wood movement: When trimming your panels and cutting the rabbet, many woodworkers simply overlook the fact wood expands and contracts mostly across its width. They give the panel expansion room all



These panels will bottom out in the groove in the rails and float in the groove in the stiles. Once the door is assembled, I like to drive a single brad through the groove and panel at the top and bottom of each panel. This brad keeps the panel centered in its frame.



Fit the rabbets on your backboards with a shoulder plane. Once they sit flat, screw them in place (you can replace the screws with nails after finishing the cabinet if you like).

around the panel in the rails and the stiles. That's not necessary. You can allow your panel to bottom out in its groove in the rails and allow for expansion and contraction in the door's stiles only.

Here's how I do this: Cut your panel and its rabbet so it bottoms out in both the rails and stiles. Then trim the long edges of your panel to get the expansion room you need in the stiles. This prevents you from cutting rabbets of two different widths. This strategy will also help prevent your panels from rattling in their grooves.

Plane or sand all your door components and then prepare for assembly. If you are drawboring your joints you can assemble this door one joint at a time if you please. This could allow you to fine



Remember this: It's easy for all assemblies to end up out of square after clamping and gluing. A little bow here and there can add up. By squaring up your frame-and-panel assemblies after gluing and before final fitting, you'll make a lot less work for yourself. The door took less than 30 minutes to fit and install in the face frame.

tune the panel's fit and tweak the fit between the rails and stiles. Or you can glue it all at once.

Fitting the Door

This door is easy to fit because you have only three edges that are critical – the stiles and the top rail. There's no bottom rail to worry about. If you followed my advice then your door should be oversized for the opening that it has to fit into. Joint one stile of the door and rip the door down so it's $\frac{3}{32}$ " smaller than its opening. Remove the same amount of material from each stile – this will require a couple cuts. Clean up the saw marks from the stile that will receive your hinges. Use your longest plane for this task.

Install the hinges on the doors. Be sure to line up the hinge barrels with the door's rails, as shown in the photo on the cover. Now you can fit the door with the hinges in place. It should be a tight fit. Prop up the door in place from below (as shown in the photo below) so that the top of the door presses against the face frame's rail. Remove one of your back boards and screw the hinges to the carcass from inside the case. Be sure to press the hinge leaf for the carcass up as you drill your pilot. This removes the slop from the barrel of the hinge, so the door will hang right



These non-mortise hinges from Amerock used to be my favorite (see Issue 1 for a review). Now these hinges are made in China and I've found some quality problems. Amerock officials insist the problem is being fixed. All I can say is that no matter what hinge you buy, make sure it swings precisely and isn't sloppy.



I cut a scrap to a close size and then added a few strips of tape to hold the door right where I wanted it from below. If there had been a lower rail, I would have shimmed the door in place from below with thin wooden wedges.

where you intended it to. Remove the prop from below the door.

Now get out a straightedge, ruler and marking knife. I mark out the gap or “reveal” directly on the door and plane to those lines. This allows me to ignore whether the door is square or a parallelogram. It will fit and look good in the end.

When you tweak the top of the door, you are going to be again planing end grain. Soak the end grain like you did when trimming the top. And work from the outside to the center to prevent chipping at the ends. You can plane the long edge of the stile with your longest plane.

Once your door fits, you can work on the shopmade cabinet stay that holds the door shut. The stay is made from $\frac{3}{8}$ "-thick scrap, a small wedge and a dowel. First take your scrap and bore a $\frac{5}{16}$ "-diameter hole through it for the dowel. Then trace the shape of the stay on the scrap and cut and shape it to your satisfaction. Now take a 2"-long section of $\frac{5}{16}$ "-diameter dowel and cut a thin kerf through its end grain. The kerf should be made with your finest saw (Japanese pullsaws work quite well here). And the kerf should be about $\frac{1}{2}$ " deep into the dowel.

Make a small wedge from hardwood. The wedge should be $\frac{1}{8}$ " thick, $\frac{5}{16}$ " wide and about $\frac{1}{2}$ " long. Put glue on the dowel and wiggle it into the hole in the stay. Now put a little glue on your wedge and tap it into the kerf until the dowel is wedged into the stay. When the glue is dry, trim the wedge flush with a saw.

Now drill a $\frac{5}{16}$ " hole in the carcass stile for the



I like a $\frac{1}{16}$ " gap or reveal. Here I'm marking that directly on the stile with a marking knife. Do the same at the other end of the door. Connect the marks and plane to that line.



Whenever possible, rest your doors on your shop floor when planing the top. Good support, a sharp iron and a little mineral spirits will make the end grain fly off your plane in unbroken ribbons.

dowel. Inside the case, mark on the dowel where it first emerges on the inside of the stile. Drill a $\frac{1}{8}$ "-diameter hole through the dowel tangent to that point. When the cabinet is finished, you'll install the stay by putting it in its hole and gluing a $\frac{1}{8}$ " dowel through that hole inside the case.

The door's knob is an off-the-rack $\frac{7}{8}$ " Shaker-style knob from Rockler Hardware.

Authentic Moulding

This moulding profile was taken directly from Handberg's drawings. He shows it made in two pieces. The top, overhanging piece with the astragal is one piece; the lower half with the cove and bead is a second piece. Suffice it to say that I couldn't find a router bit that would mill this lower profile. So I made the moulding from three pieces: The top overhanging piece, a coved piece and a beaded piece. With some careful wood selection, it will look like one piece.

There was one other change I made to the moulding. The original moulding was flush to the top edge of the cabinet. This meant that you had a lot of joinery showing up there, and if your joinery isn't perfect, you'd be showing it off. So I cut a $\frac{1}{2}$ " x $\frac{1}{2}$ " rabbet on the underside of the top cap moulding. This does several things (all good): It hides a lot of end grain on the top. It conceals the fit (good or bad) between the moulding and the case. And it adds a lip to the top of the cabinet. I like the lip, which helps keep objects from spilling to the floor.

The moulding can be milled using three common bits (see the Supplies box for details). Once you get the router work complete, mill the rabbet on the top cap moulding. Install the moulding by fitting the front piece first. It's the most critical length of moulding on the whole piece.

With that piece of moulding sized perfectly, you can glue and nail it in place with the spacer scrap supporting the moulding on one end. Then things get easy. Miter the front ends of the mouldings that travel across the sides of the case, commonly called the “returns.” When the miters are tight, mark where they meet the back edge of the carcass. Trim them square, then glue and



To install the length at front, first cut a scrap piece of moulding with perfect 45° ends as shown. Butt the front moulding against this scrap at one corner and mark at the other end where the moulding touches the corner of the carcass. Miter at that mark. Then attach the front piece.



Although I really like my hammer and cut nails, I like my headless 23-gauge pinner just as much for installing small mouldings such as the beading on this case.

nail them to the case (watch out for the nails in the carcass). Turn the case upside down on your bench and install the cove moulding using the same strategy.

The rest is just finishing things up. Break the edges with sandpaper and decide on a finishing strategy. If you're going to putty your nail holes, I recommend you do this after finishing. There's putty designed just for this (commonly available at every home center) and it allows you to mix and match the color closely.

Both of these cabinets are in my home now awaiting their final owners. What's curious about them is that building them actually created a few mysteries rather than unraveling them. The shelf arrangement is quite curious. The irregular and unexpected spacing makes me wonder what was stored in the original. Most people take one look at this cabinet and say “jelly cupboard” or “pie safe.” But I'm not so sure. **WM**

— Christopher Schwarz

Supplies

Freud

800-334-4107 or freudtools.com

Freud router bits

- $\frac{3}{16}$ "-radius half-round bit
#82-104 (cuts large astragal)
- $\frac{5}{8}$ "-radius cove bit
#30-107 (cuts cove)
- $\frac{1}{8}$ "-radius half-round bit
#82-110 (cuts small bead)
- $\frac{1}{8}$ "-radius beading bit
#80-122 (cuts bead on stiles and backboards)

Rockler

Rockler.com or 800-279-4441

- 1 ■ Cherry Shaker $\frac{7}{8}$ " knob
78493, \$2.99/pair

Prices correct at publication deadline.

Shaker-inspired Bench

Some simple adaptations turn this
19th-century bench into a modern
mudroom necessity.

There is an old Shaker hymn called “Simple Gifts” that begins with this line: “Tis the gift to be simple.” This bench carries many of the qualities that the Shakers valued. The design is straightforward and driven by function, yet it’s also graceful and elegant. The construction is obvious and building it doesn’t require anything beyond simple tools and techniques.

The antique Shaker bench that inspired this piece actually led two lives. It was originally made without a back at the Hancock Shaker village. As it got older (and presumably the brothers or sisters using it also got older) wood was scabbed onto the back of the ends, and the backrest was added, making it more comfortable.

Made of pine, the original was longer—94”—and likely was used with a dining table. I liked the look and simplicity of this piece, but I decided to make a shorter version for use in an entry hall or mudroom.

I used cherry, and happened upon a single board that was wide enough, and long enough, for the seat and the end pieces. If you’re not as fortunate, you’ll need to glue up stock for width, which is what I was planning to do on the way to the lumberyard.

by Robert W. Lang

*Comments or questions? Contact Bob at 513-531-2690 ext. 1327
or robert.lang@fwpubs.com.*



Adapting the Design

The original seat was 1" thick, and the corbel supports were short pieces at each end. Because I would be using $\frac{3}{4}$ "-thick materials, I extended the seat supports to run all the way between the ends to brace the seat and strengthen the overall structure.

The second design change was to the ends – on the original the arched cutout that creates the legs of the bench wasn't centered on the end. Because the back was added, the cutout was pushed forward. I put the cutout at the mid-point of the ends and made it taller and elliptical.

This T-square jig locates the exact position of the router bit. The addition of an end stop on the bottom of the jig puts the cuts the same distance from the ends of both the seat and the back rail.



Easy Layout, Strong Joinery

I stayed with the simple joinery of my example; a dado in the bottom of the seat to capture the ends and two more in the back rail to capture the back supports. Lap joints where the seat supports meet the ends complete the joinery.

After all the parts were cut to size, I routed the $\frac{3}{4}$ "-wide x $\frac{1}{4}$ "-deep dados in the bottom of the seat, and the back of the back rail. I made the T-square jig as shown at left to guide the router, and to locate all of the joints the same distance in from the ends.

With the dados cut, I made a test assembly of the two ends and the seat. When I prepared the stock, I planed everything to just more than $\frac{3}{4}$ ". I made some final adjustments to the thickness of the ends with a hand plane to get a nice snug fit in the dados.

With these three pieces fit together, I turned them upside down on my bench. After making sure that the ends were square to the seat, I marked the seat supports' locations working from the ends, as shown below left.

While I managed to avoid having to measure for the locations of the lap joints on the stretcher, I did need to measure for the depth of the cuts. Because the ends recess into the $\frac{1}{4}$ " dado in the seat, the lap joint cuts need to be $\frac{1}{8}$ " deeper than half the width of the support rails. The cuts in the rails and ends were marked at $1\frac{7}{8}$ " using the end of my adjustable square.

Guiding Hand Tools

Like the dados in the seat, there are numerous ways to cut the lap joints. The seat supports are rather long, so I decided not to risk using



With the ends placed in the dados in the bottom of the seat, you can mark the location of the lap-joint cuts in the seat rail without measuring.

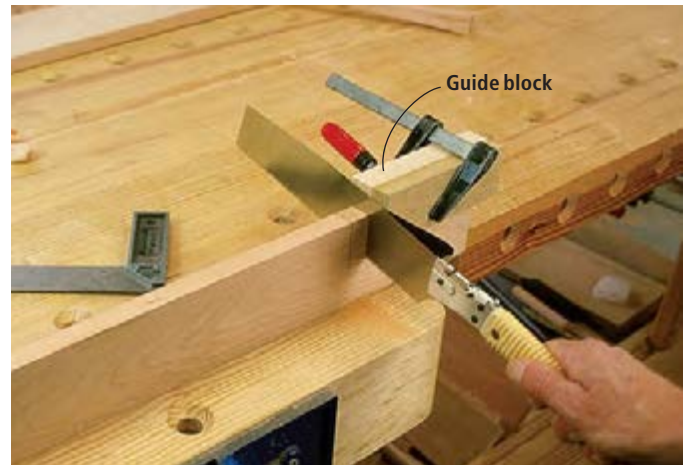

Clamp the guide block for the saw to just cover the pencil lines. By pressing the saw to the block as the cut is started, you establish a straight kerf.

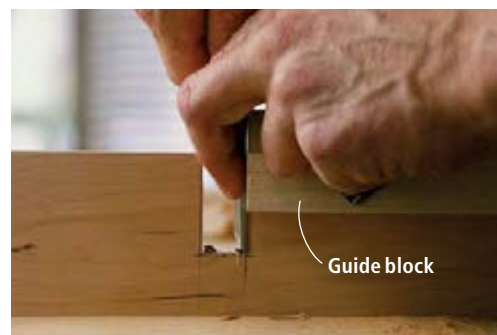

After the bottom of the joint has been cut, use the same guide block to guide the chisel to pare the sides of the joint.

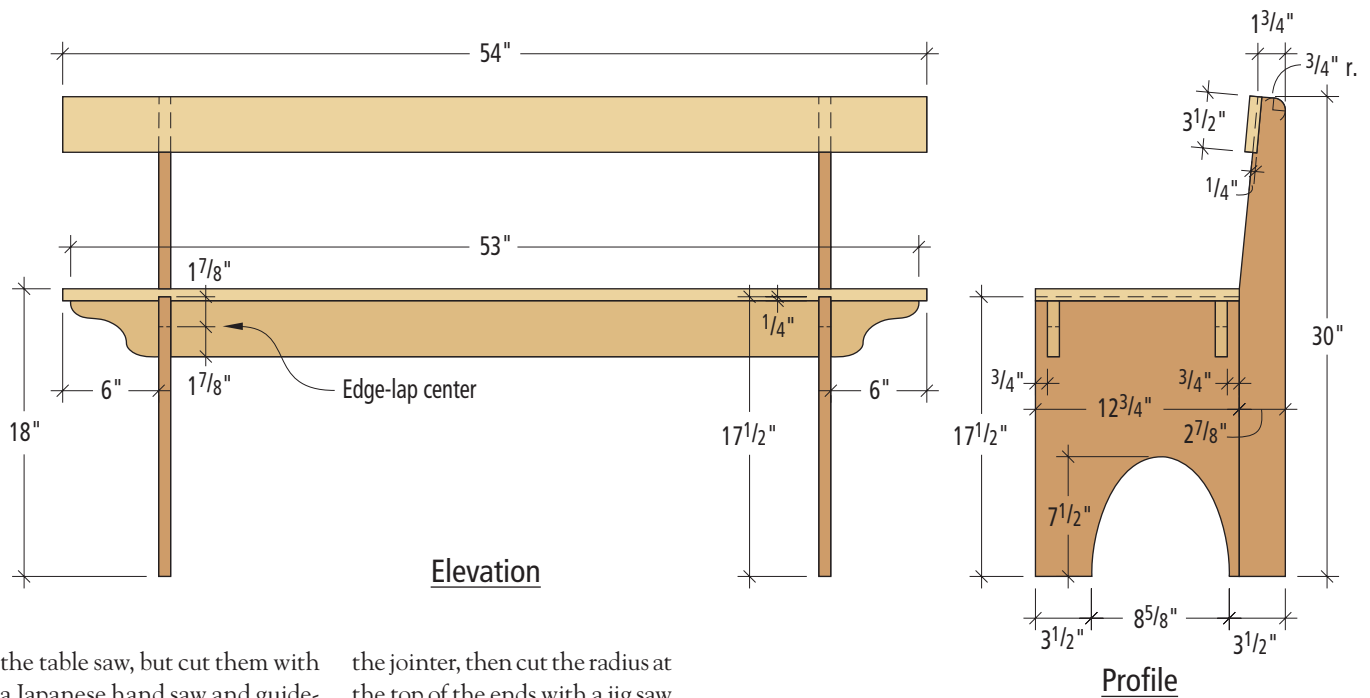

the table saw, but cut them with a Japanese hand saw and guide-block as shown at left. With the guide block clamped on the edge of my layout lines, it was easy to keep the saw straight, and I had the long cuts made quickly.

I used a jigsaw to make the bottom cuts, but I could just as easily have used a coping saw. I used the same guide block to pare the sides of the joints with a chisel, as shown at left. I also used a rasp to fine-tune the fit. These joints are relatively easy to make, but you need to be careful – if you try to force them together, there is a good chance that the pieces could split, especially with cherry.

I like to sneak up on a good fit by testing the slots next to the adjacent slot rather than in them. If the wood should split, don't despair. You can usually glue the split pieces back together without losing any strength, or the repair ever being visible.

With the lap joints complete, I turned to the back supports. By making them as separate pieces, cutting the back taper is very simple. I used my band saw and started the taper 1/4" above the intersection with the seat, tapering to 1 3/4" at the top of the support. After making the cuts, remove the saw marks by running the pieces over

the jointer, then cut the radius at the top of the ends with a jig saw or coping saw.

To make the ends a single piece, I simply glued the back supports to the ends. I used a butt joint, and had to be careful while clamping this up to keep everything aligned. You might want to add some biscuits to help keep the pieces in the same plane. Once the glue was dry, I cleaned up the joints with a card scraper, and I was then ready to cut the decorative curves.

I made a full-size pattern of the cutout in the ends, and the corbel at the end of the seat supports. I transferred the patterns to the pieces and then made the cuts with a jigsaw. I cleaned-up the cuts by sanding the curves with an oscillating spindle sander. Again, there are many ways to make these cuts and smooth the surfaces. A band saw or coping saw could have made the cuts, and the curves could be smoothed with a spokeshave, a card scraper or a sanding block.

Edges with Character

I prefer to ease the sharp edges on a piece like this by hand with a block plane, and I did most of this before assembling the bench, being careful to avoid the areas

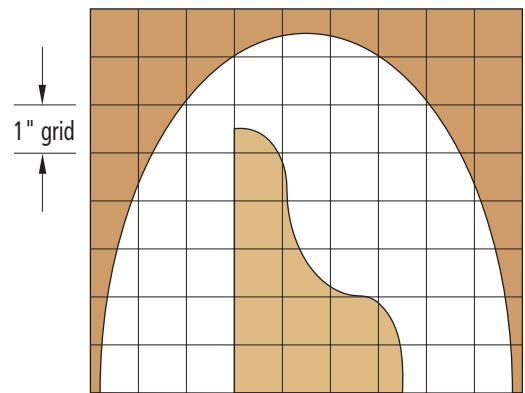

Quarter-size patterns



After the joints are cut and the back extension is glued on, position the paper pattern and mark the arched cutout.



The oscillating spindle sander is ideal for cleaning up the saw marks and sanding to the inside of the pencil line.



A spokeshave eases the edges the block plane couldn't reach.

The lap joints should slide together with hand pressure and don't need to be clamped together. Speed squares clamped in the corners keep the assembly from racking while the glue dries.

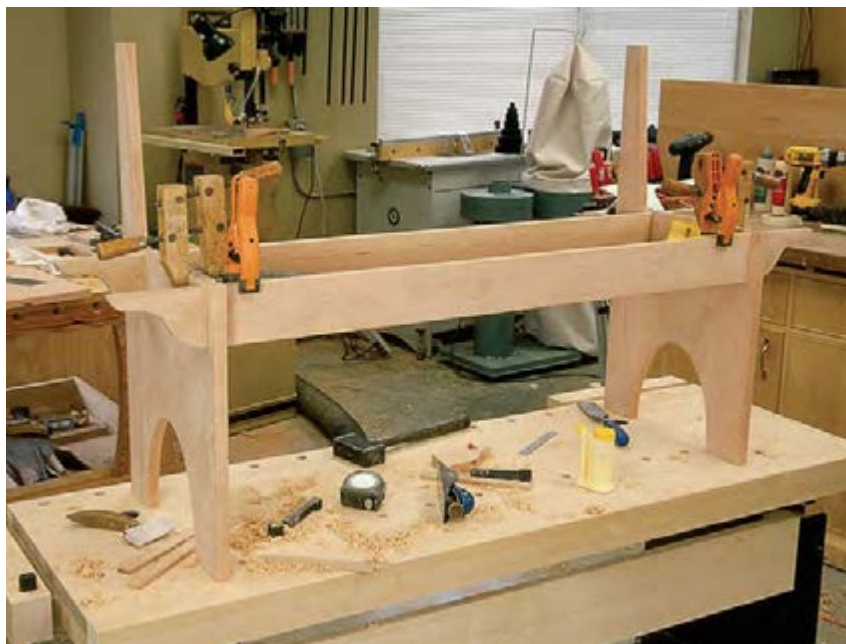

in the vicinity of the joints. I could have used a router with a roundover or chamfer bit, but I enjoy the process of doing it by hand, and I like to vary the radius in different areas, adding character to the piece. With a router, I would have ended up with a sterile sameness on every edge.

The edges on the inside curves of the end cutouts were shaped with a spokeshave as shown in the photo below. After everything was put together, the edges near the joints were eased with a knife, a skew chisel and a rasp.

I did most of the sanding before assembly, sanding to #150 grit by hand with a sanding block. I avoided sanding in the areas of the joints to keep the joints from becoming sloppy. While hand sanding can be tedious, it leaves a much better surface, particularly on narrow edges, than using a random-orbit or palm sander.

Because the lap joints have a good deal of mechanical strength, I didn't need to clamp them together. I did clamp a "speed square" in the corners to keep things from racking while the

glue dried. After an hour, I put glue on the top of the end pieces, and the top of the support rails. Then I clamped the seat and back, and left the assembly overnight for the glue to dry.

A Bit of Insurance

In the photo of the original Shaker bench, the ends of the dowels or plugs are visible on the face of the back rail and on the front edges of the joints for the seat supports. I decided to reinforce these joints, as well as the dado in the seat, with #8 x 1³/₄" screws, covering the screw heads with contrasting plugs of black walnut.

Years ago I did repair work on wooden boats, and plugged screws were the way we held nearly everything together. Here are a couple of tricks from those days that speed the process considerably.

Most people cut plugs in a random pattern in a piece of scrap and then pry them out with a chisel. If you rip the scrap to roughly the outside diameter of the plug cutter, and use a fence on the drill press as shown on page 43, the plug cutter won't need to remove so much material, and it won't tend to wander.

The second benefit is that the plugs don't need to be pried loose with a chisel. Set the blade height on the table saw to 1/8" less than the strip of plugs, and set the fence so that the plugs are on the outside of the blade. Use a push stick to carefully make the cut, and you have a strip with the plugs still attached. You can easily break them off when you're ready to use them, as shown on page 43.

Flush-cutting handsaws can be used for trimming the plugs, but I prefer to use a chisel. Pay attention to which way the grain is running on the side of the plug, and make the cut with the edge of the chisel on the "downhill" side. I hold the chisel slightly above the surface,

and one smack with a mallet removes most of the plug. A paring cut, pushed by hand, leaves the plug flush with the surface.

If I'm not sure which way the plug will break, I'll make the first cut higher up, so that the plug is entirely above the surface, and then make the final cut in the direction that the first cut broke, as shown below. This technique is faster than sawing, and a minimal amount of work with a scraper leaves the plug smooth and flush with the surface, as there are no saw marks to be sanded out.

A Fitting Finish

With the entire piece assembled, it was time to finish the work on the edges of the bench and to give everything a final sanding. I sanded all of the edges with #120-grit sandpaper, followed by #150. With the majority of the flat sur-

faces sanded to #150 grit before assembly, only some minor sanding was needed before the entire piece was hand sanded with #240-grit sandpaper.

Cherry is truly a beautiful wood, and it's my opinion that an oil finish brings out the best of its character and figure. I used a Danish oil finish, and wiped it on, working in the oil with a nylon abrasive pad, and keeping the surface wet for about 45 minutes.

After wiping the surface dry with a rag, I set the bench in the sun for a few hours, turning it every half hour and wiping off any oil that bled out. This exposure to the sun darkened the wood, giving a jump start to the patina that cherry develops as it ages.

The next morning I applied a second coat of oil, keeping the surface wet for 20 minutes before wiping it dry. I let the oil dry during a long weekend, and applied two coats of paste wax, worked in with

a nylon pad and then buffed.

We tend to think that the furniture we sit on needs to be intricate in design and complicated to build. This Shaker bench proves otherwise. **PW**



Spend a little time preparing stock for plugs, and they will be easier to cut. The rabbet in the fence keeps chips from building up.



Keeping the plugs barely attached to the strip keeps them manageable. Break them off from the strip by hand.

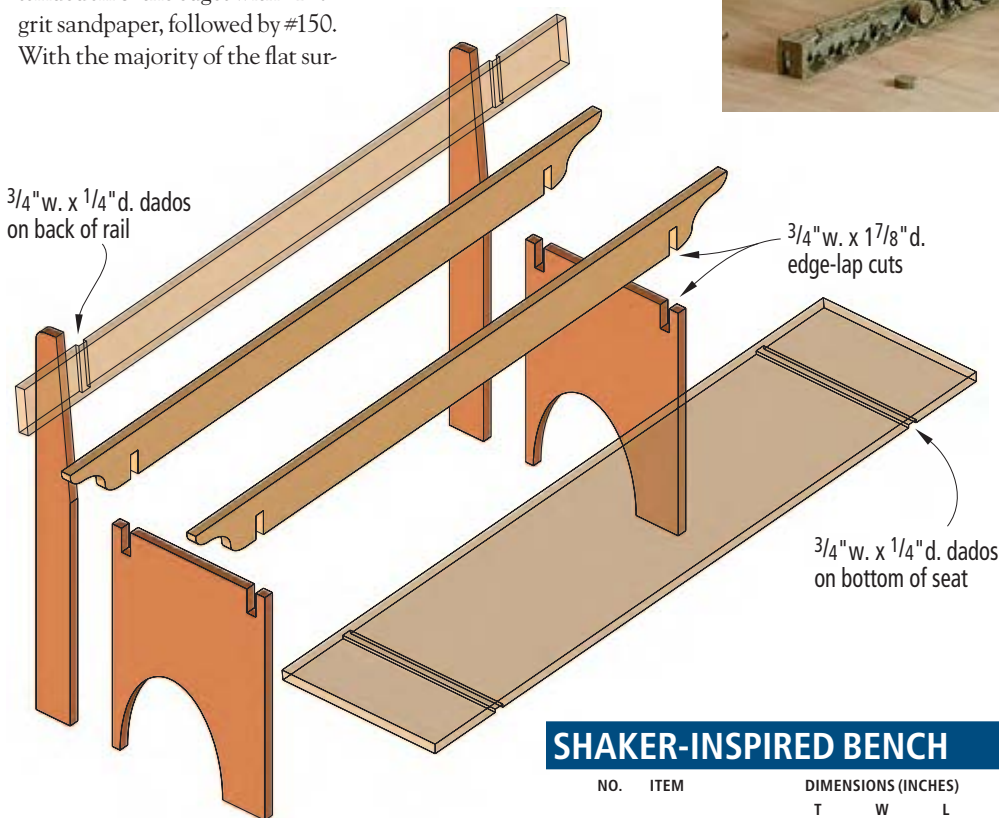

Exploded view



It's faster to trim the plugs with a chisel than with a saw, and if you keep an eye on the grain direction they will be flush with the surface.

SHAKER-INSPIRED BENCH

NO.	ITEM	DIMENSIONS (INCHES)			MATERIAL	COMMENTS
		T	W	L		
□ 2	Ends	3/4	12 3/4	17 1/2	Cherry	
□ 2	Back supports	3/4	2 7/8	30	Cherry	Glue to ends after joints are cut
□ 1	Back rail	3/4	3 1/2	54	Cherry	
□ 2	Seat supports	3/4	3 1/2	53	Cherry	
□ 1	Seat	3/4	12 3/4	54	Cherry	

Get More Great Woodworking Resources!

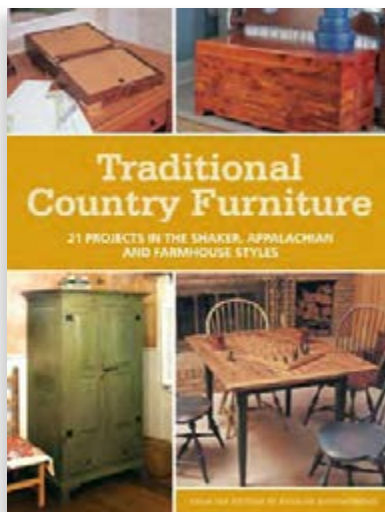

Your free download is an excerpt from the **Spring 2004** and **Spring 2006** issues of *Woodworking Magazine* and the **December 2004** issue of *Popular Woodworking Magazine* and is just a sample of the great Shaker projects you can find in the ShopWoodworking.com store. Buy more projects today, and continue building your knowledge!

**Buy the full contents today,
and continue building
your knowledge!**